

Characterization and preservation of the “gaiola” construction. An overview.

Vítor Cóias

(vitorcoias@stap.pt)



By the time of Lisbon's 1755 earthquake, timber framed buildings existed already for many centuries in Europe (for instance, "fachwerk" houses in northern Europe), as a common construction system, not related to earthquake resistance. In other areas where earthquakes are frequent, as in the Balkans, timber framed walls (for instance, "bondruk"), had become widespread, because, after each earthquake, people observed that they had resisted better and copied them.

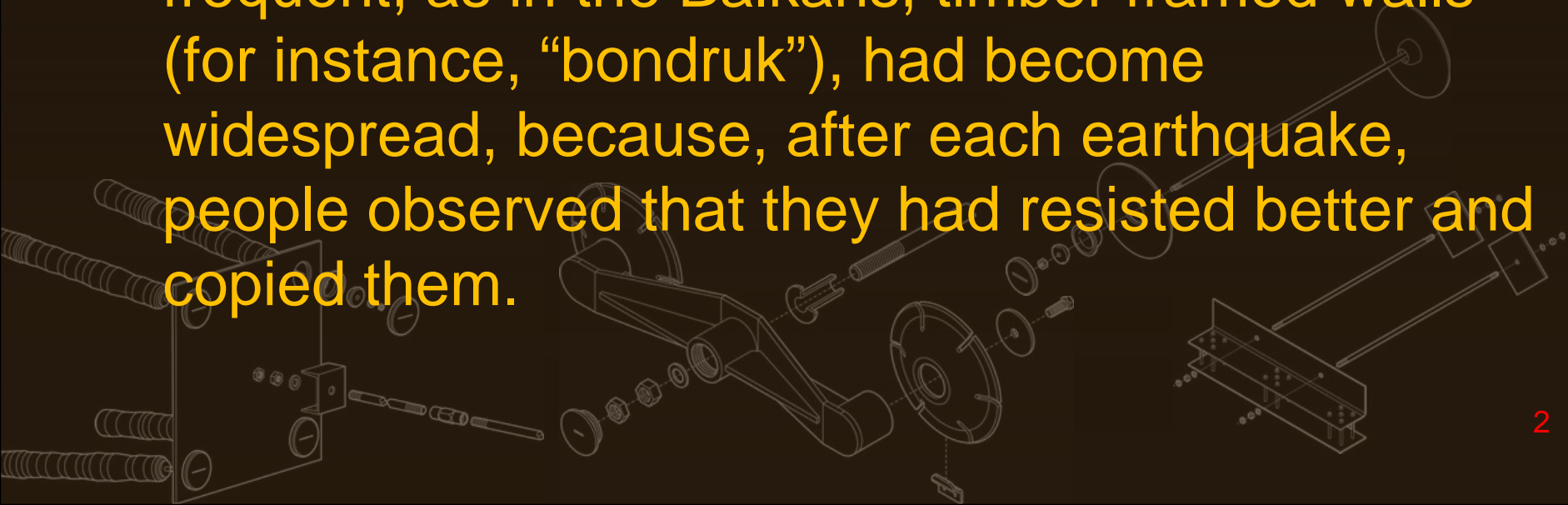



← fachwerk
bondruk ↓



In his Encyclopaedia, Diderot included drawings of timber framed walls, although they were intended as façade walls, not as interior bracing walls.

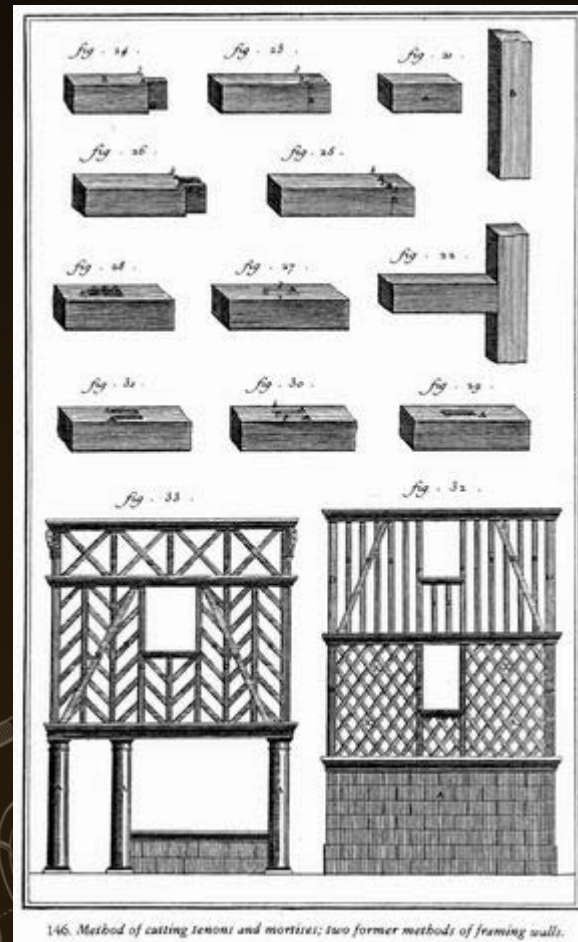
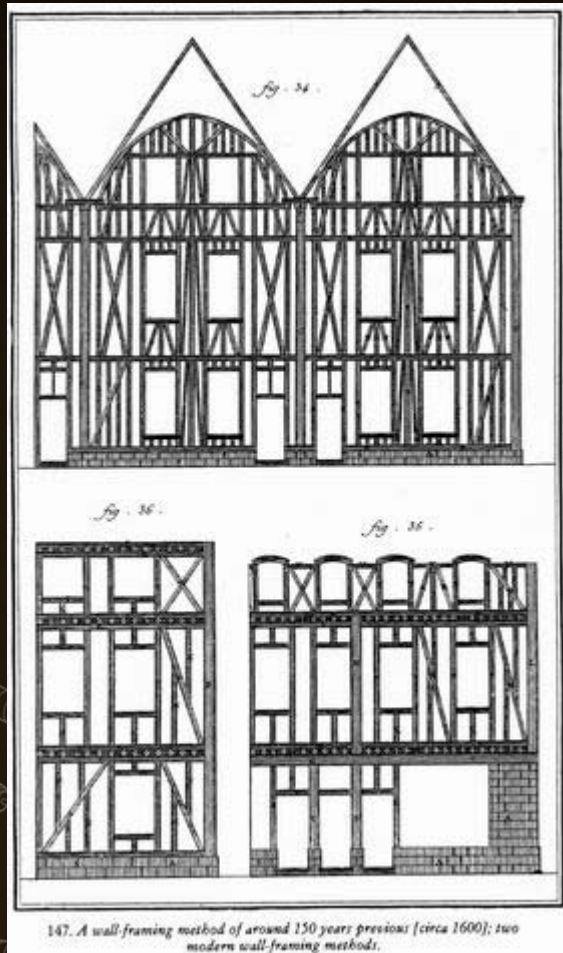

After the 1755 earthquake the construction methods in Lisbon (and elsewhere in seismic areas of the country) changed substantially. A number of structural features intended to give the new buildings a better seismic behaviour was devised by the architects and the master carpenters so far involved in shipbuilding. Although no written guidelines have been found, the use of those features became widespread and the following generations of master builders (masons and carpenters), respected them thoroughly well into the late 19th century.



Buildings where grouped in very regular blocks, with proportions in accordance with present time seismic design guidelines.

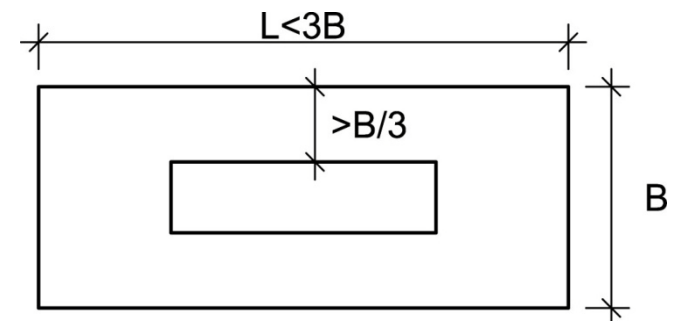

A sturdy tri-dimensional interconnected timber bracing system was erected by the carpenters before the masons started their work. The imposing cage-like structure gave rise to the designation “gaiola” which thereafter describes this type of construction.

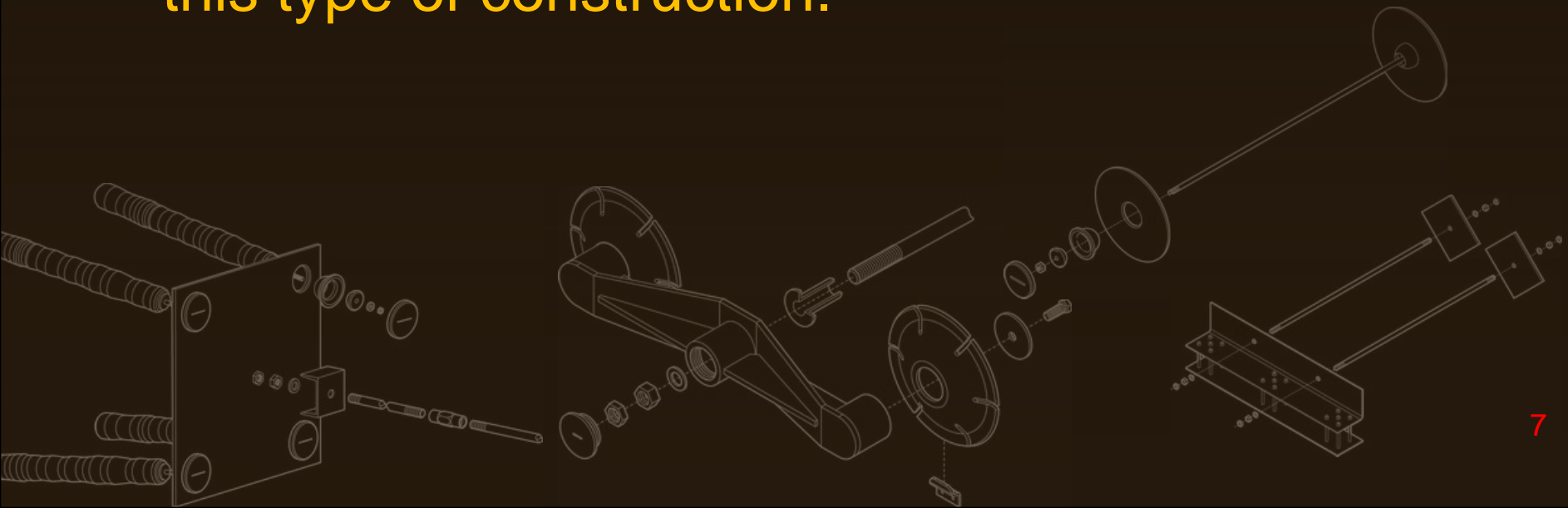

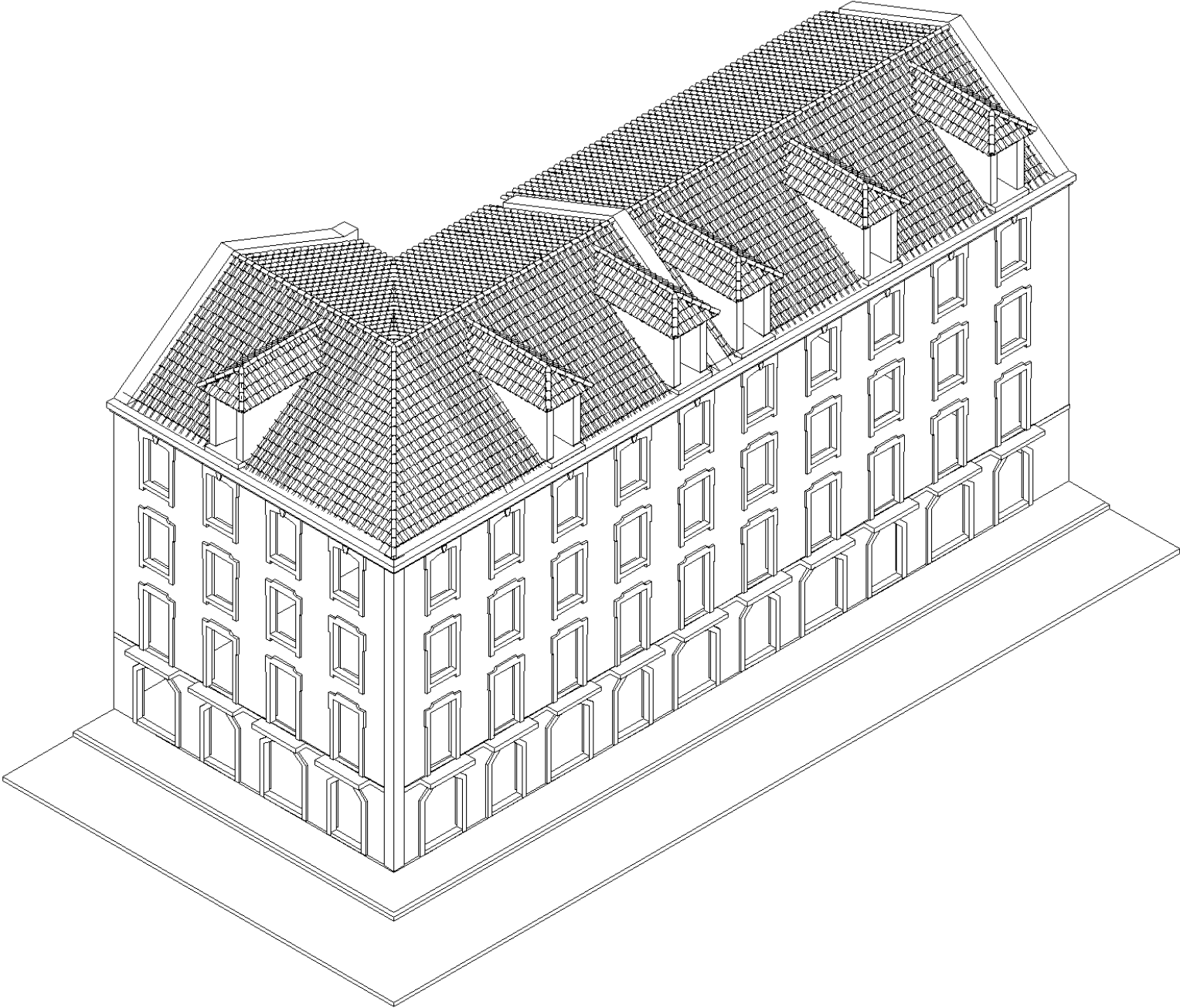

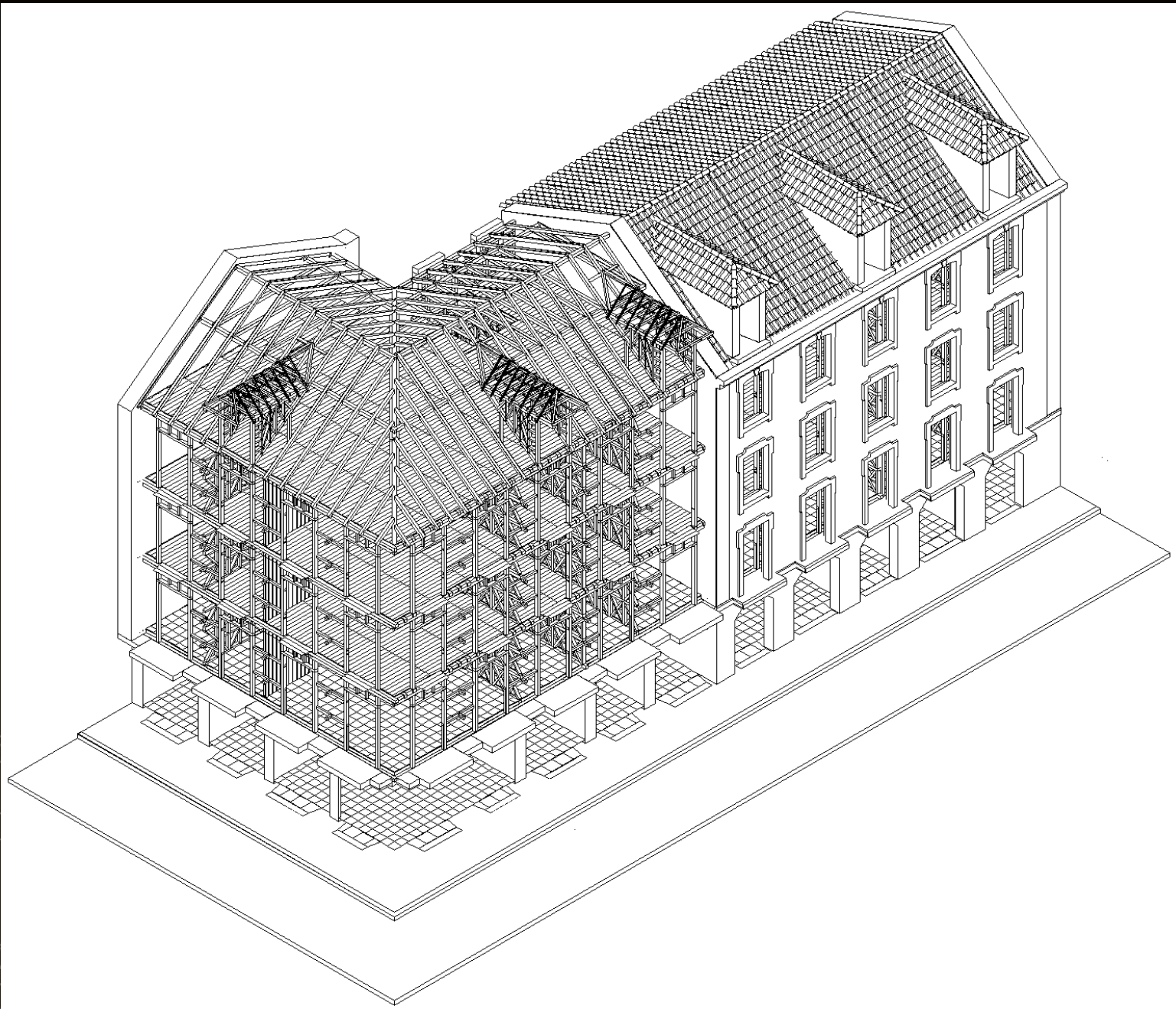

Rubble masonry
fills the spaces of
the trussed walls
for damping. ↓

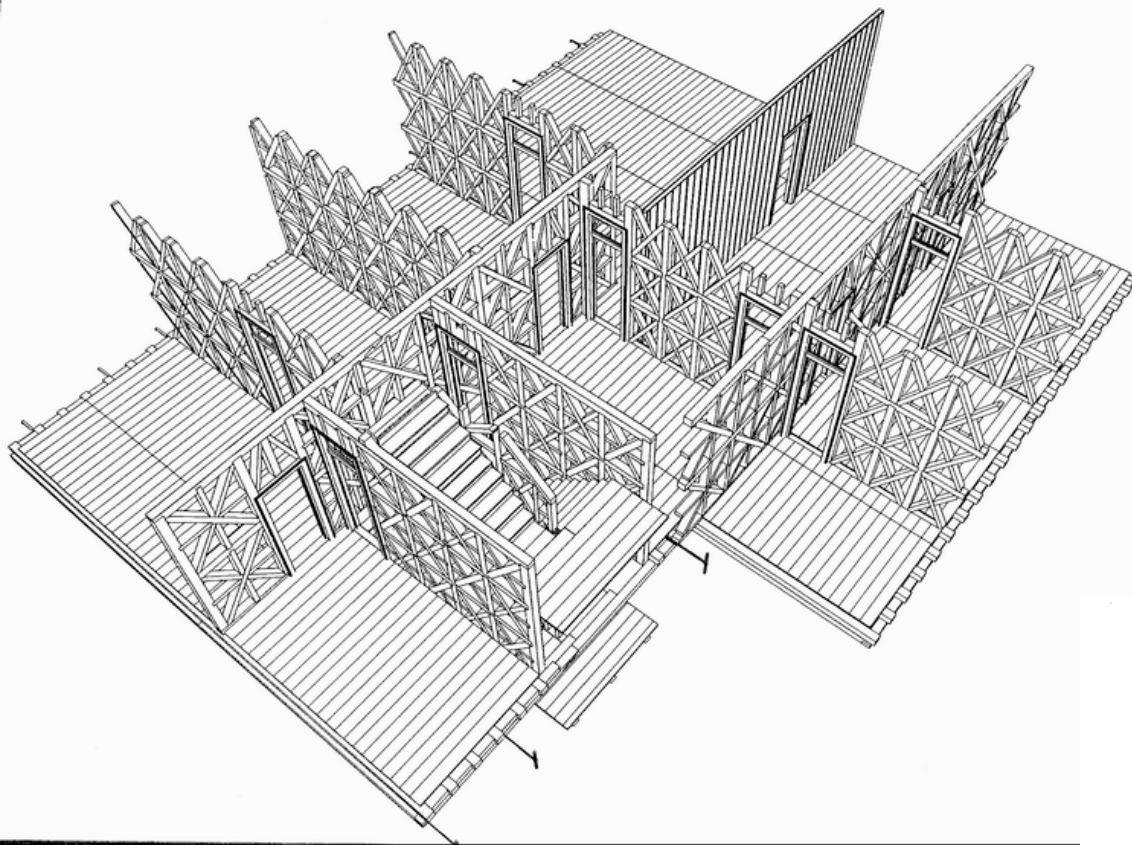

↑ Basic tri-dimensional
bracing unit: diaphragm
floor and bracing walls in
two directions.

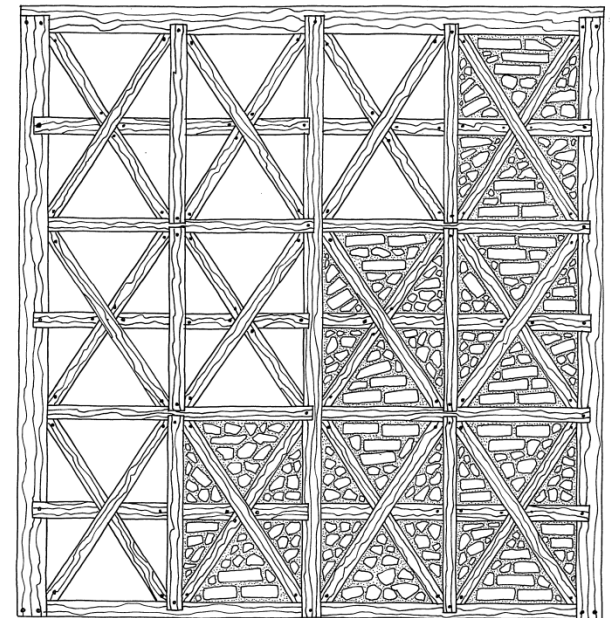



Sturdy bracing of floor joists to ensure diaphragm action. Steel members shown result from more recent alterations.



As it was felt that good connection between structural components was paramount for bracing effectiveness, a set of wrought iron ties was introduced, interconnecting floors, timber-framed walls and main masonry walls.

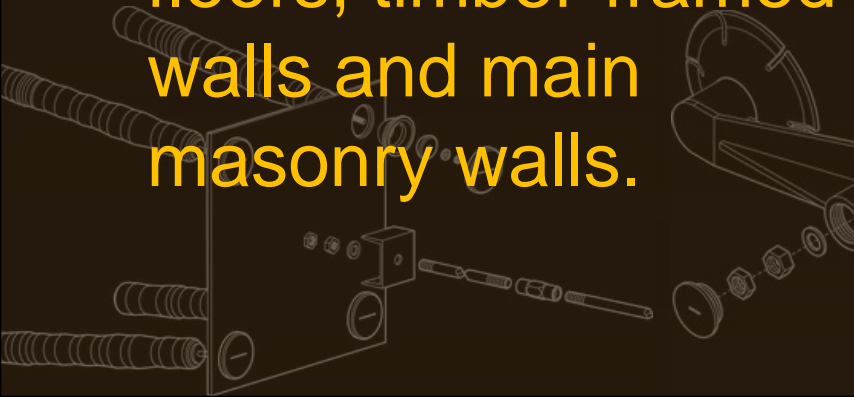



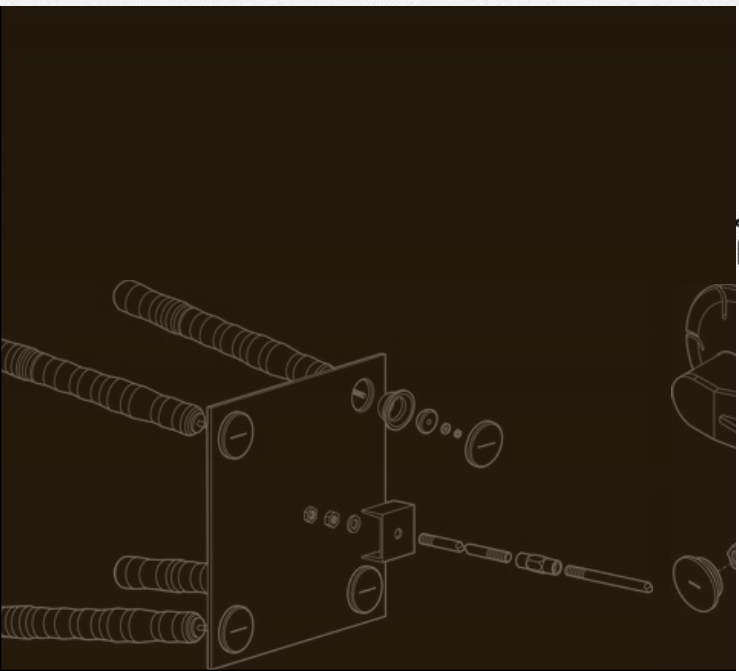
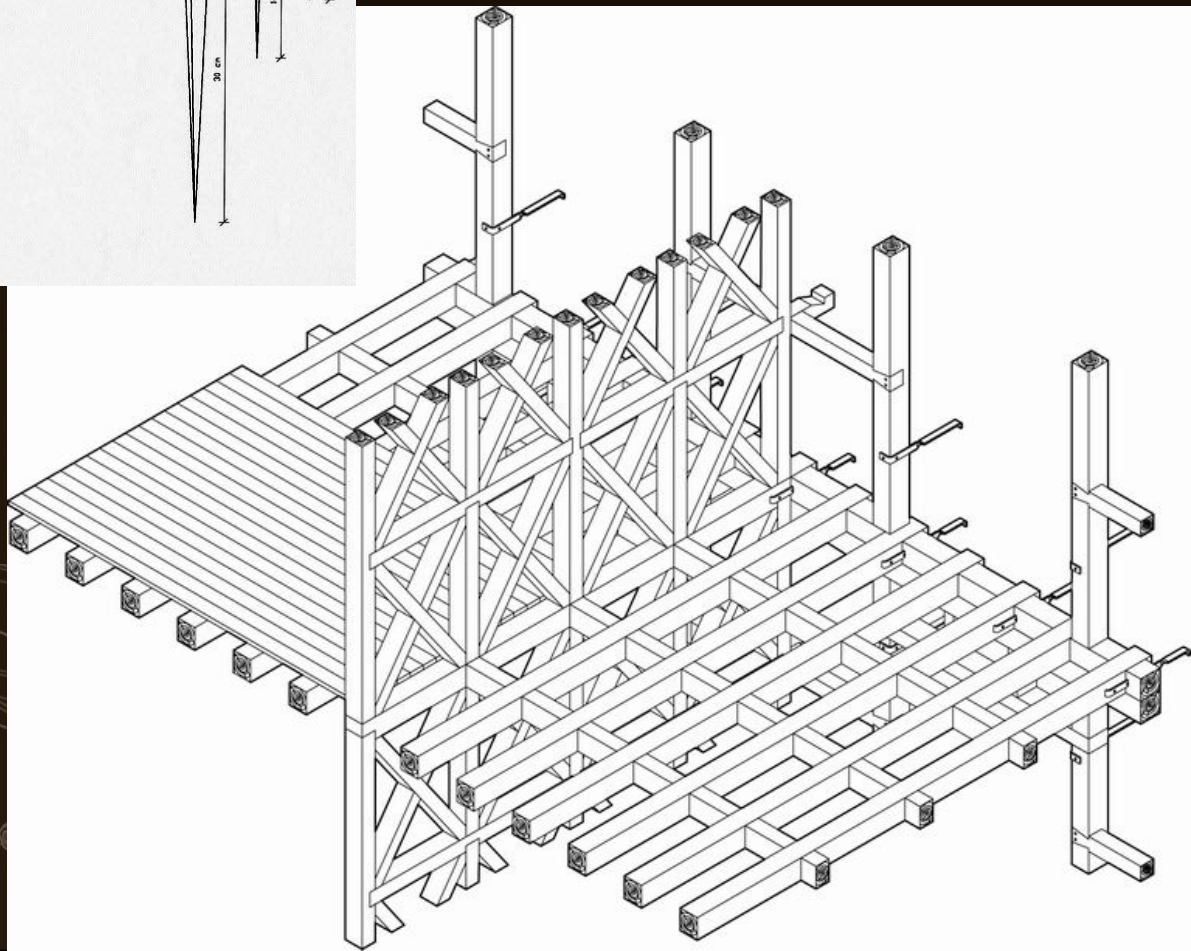
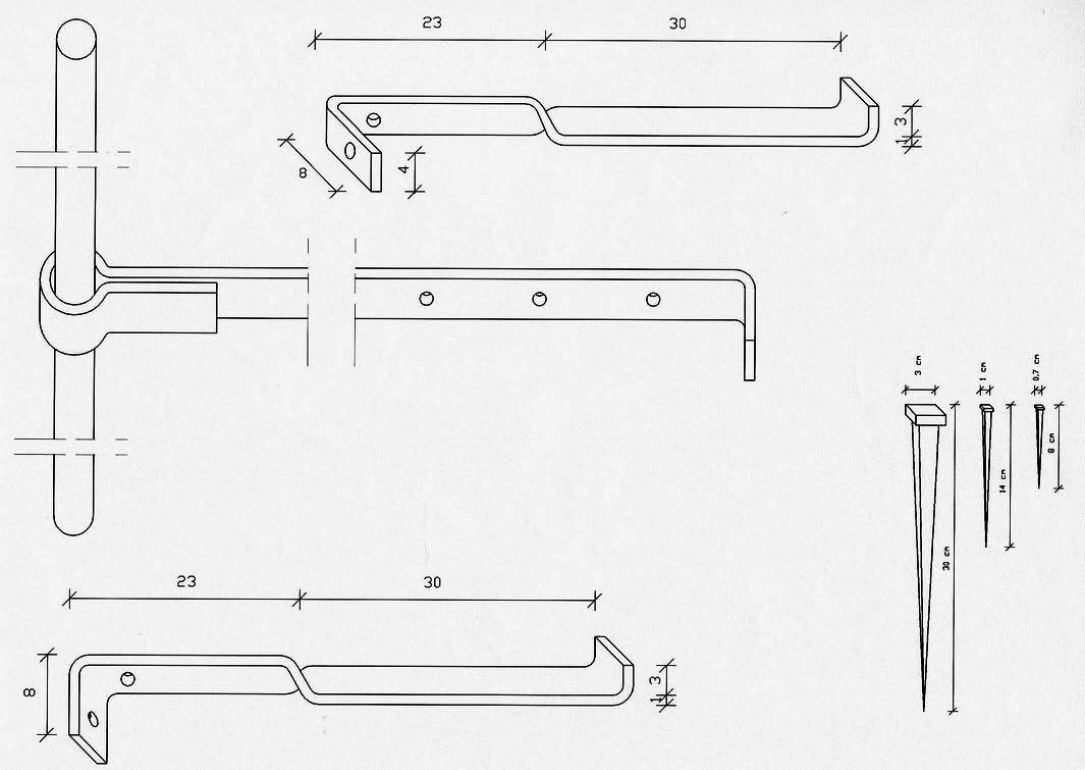

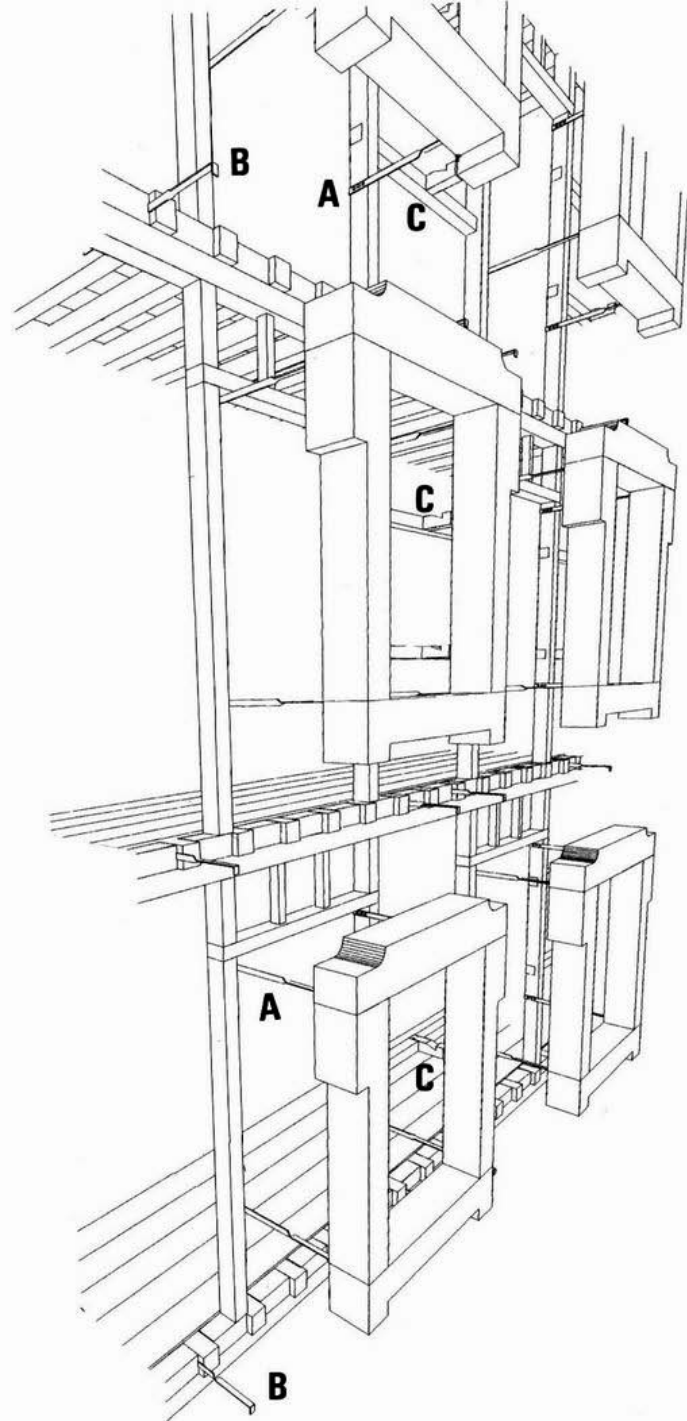

In this figure, where the masonry of the main façade wall was made invisible, several connectors are shown, both in iron (A, B), or timber (C). Masonry confinement between interior timber grid and exterior ashlars is also noted.

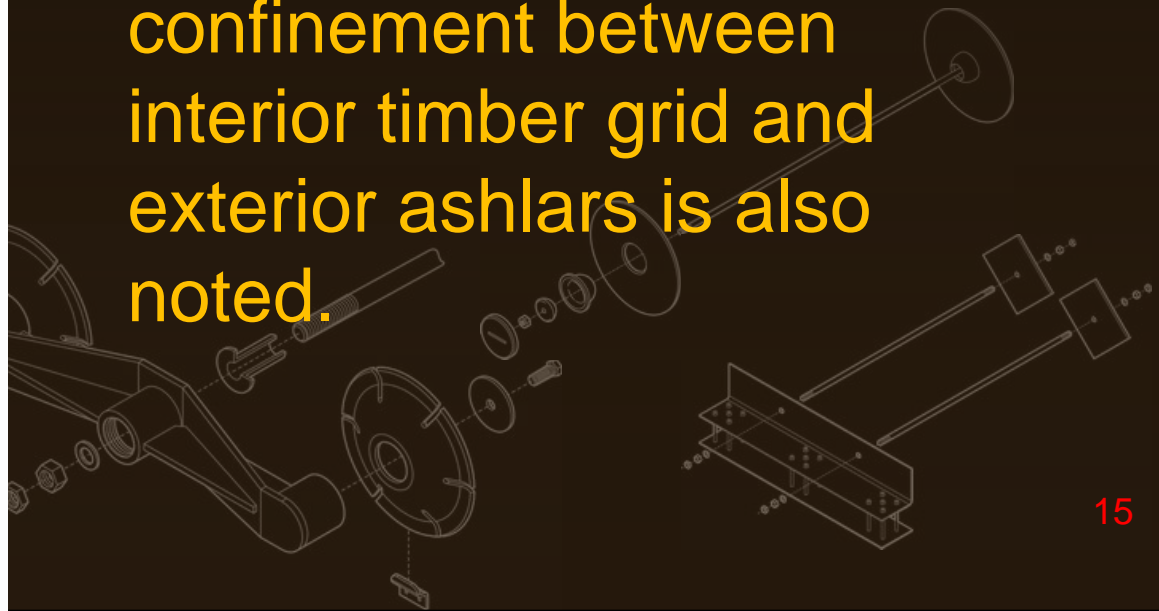

In spite of all the above mentioned features, in situ and laboratory tests, along with structural analysis using standard software, uncover a certain number of shortcomings of the “gaiola” system:

- Marked stiffness difference between the first floor and the higher floors, due to the use of different materials and structural solutions: masonry vaults and arches in the first floor, timber joists in the upper floors;
- Low quality masonry in the main walls;
- Insufficient connections between timber bracing elements and main masonry walls.

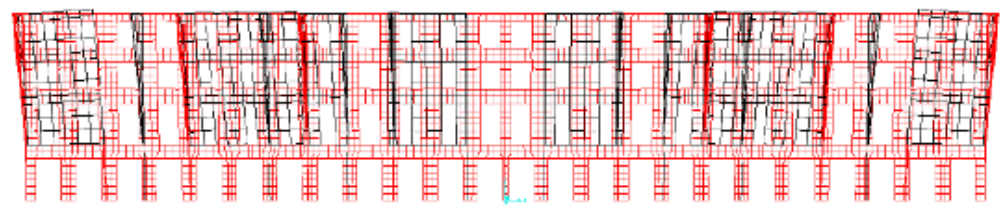
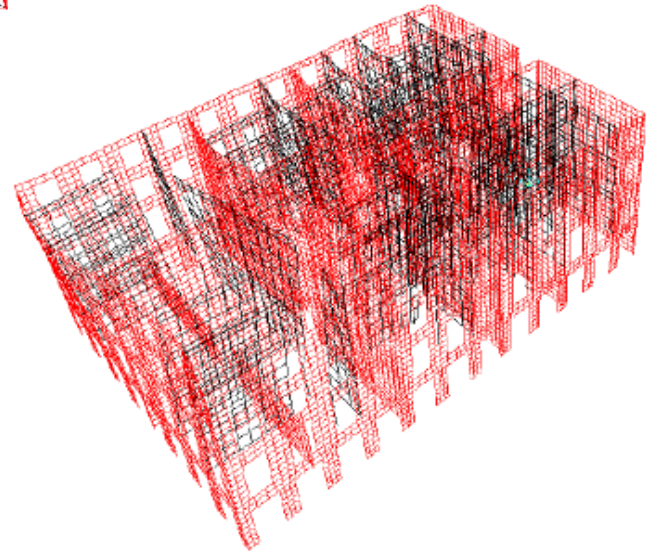
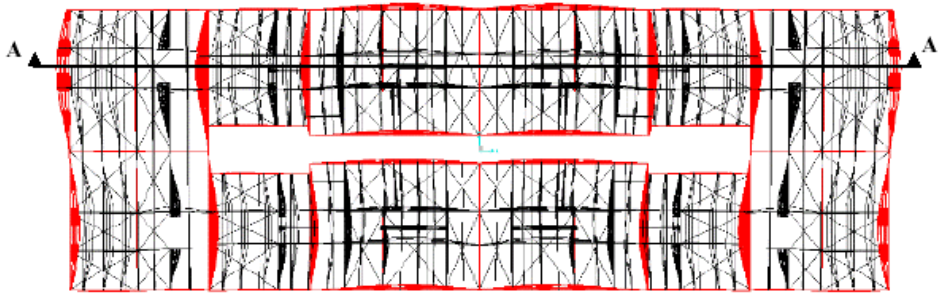

Elastic modelling
of a pombalino full
block.

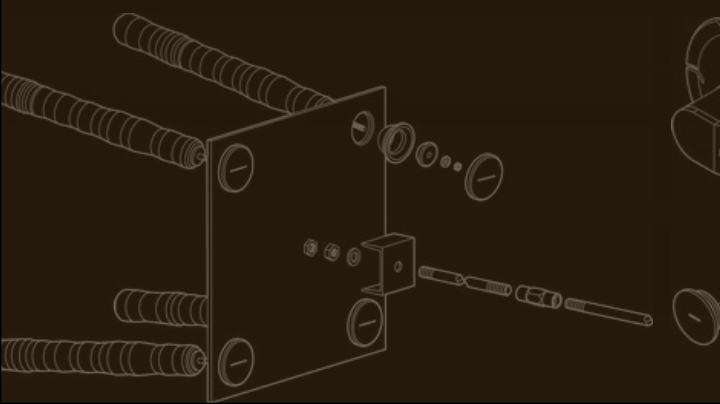

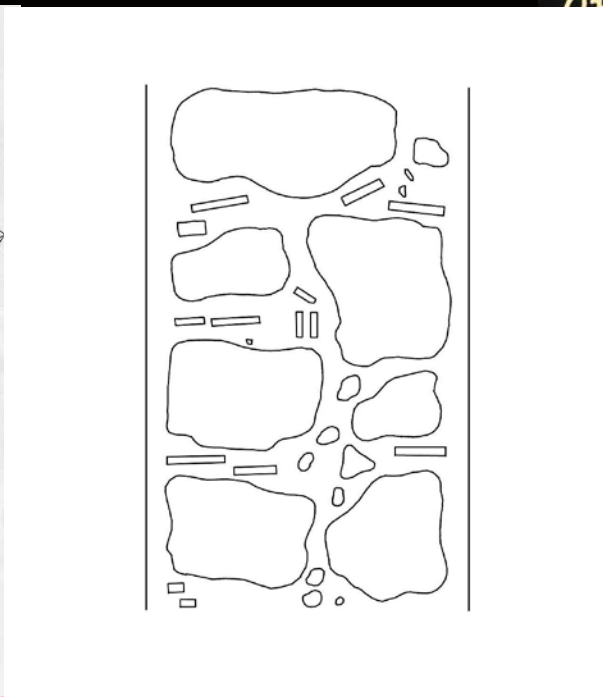
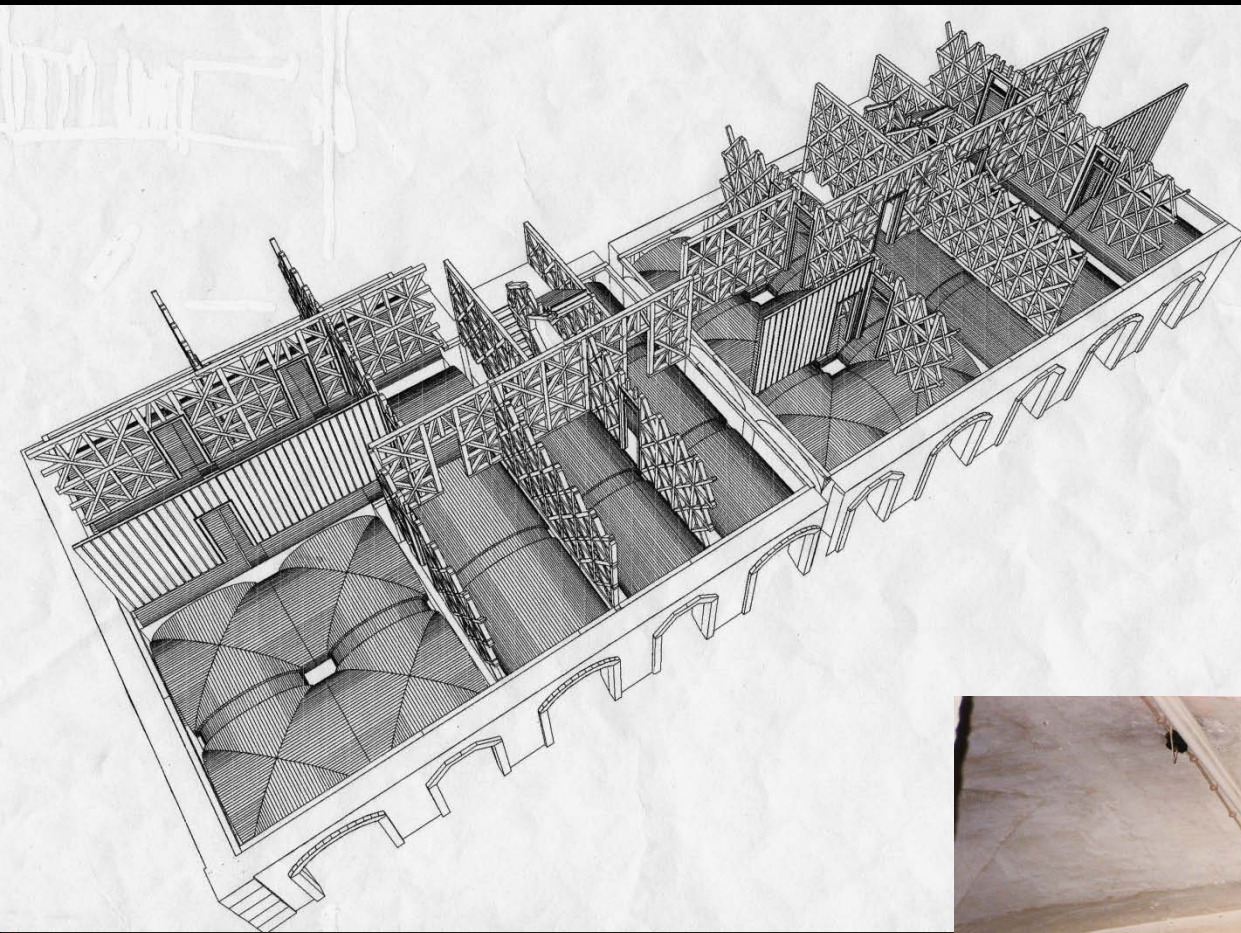

Structural irregularity of pombalino buildings. Low grade rubble masonry walls (above, right).

Besides, many buildings have been degraded by lack of maintenance, and have suffered deep man made alterations, as the replacement of the timber braced walls by reinforced concrete members, the cutting of large openings, the addition of extra floors and the under-excavation to construct basements.





Removal of façade piers.



Wood degradation. Rot promoted by excess moisture.



Main anomalies of pombalino buildings.



Alteration of the structural system with replacement of masonry components by reinforced concrete.



Addition of extra floors.

Main anomalies of pombalino buildings.

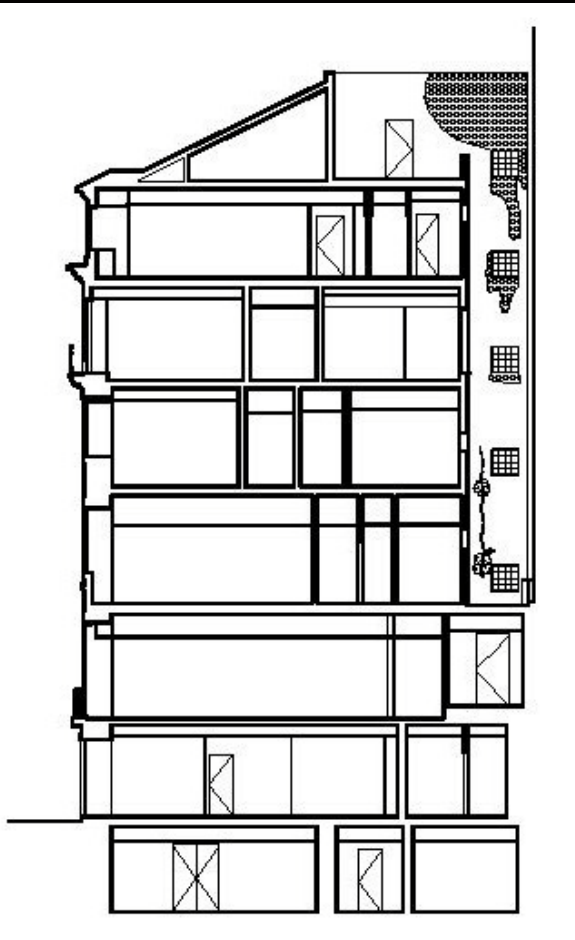

Execution of new RC slabs
at ground level.

Excavation of soil underlying the building,
with foundation deepening and basement
construction.

Main anomalies of pombalino buildings.



Total demolition of the building core and execution of a new steel or reinforced concrete structure.

Intrusive rehabilitation methods.

Low intrusiveness:

- The intervention should be as little intrusive as possible, meaning that it should cause the minimum disturbance of the integrity and stability of the building, of its functions and of its users.

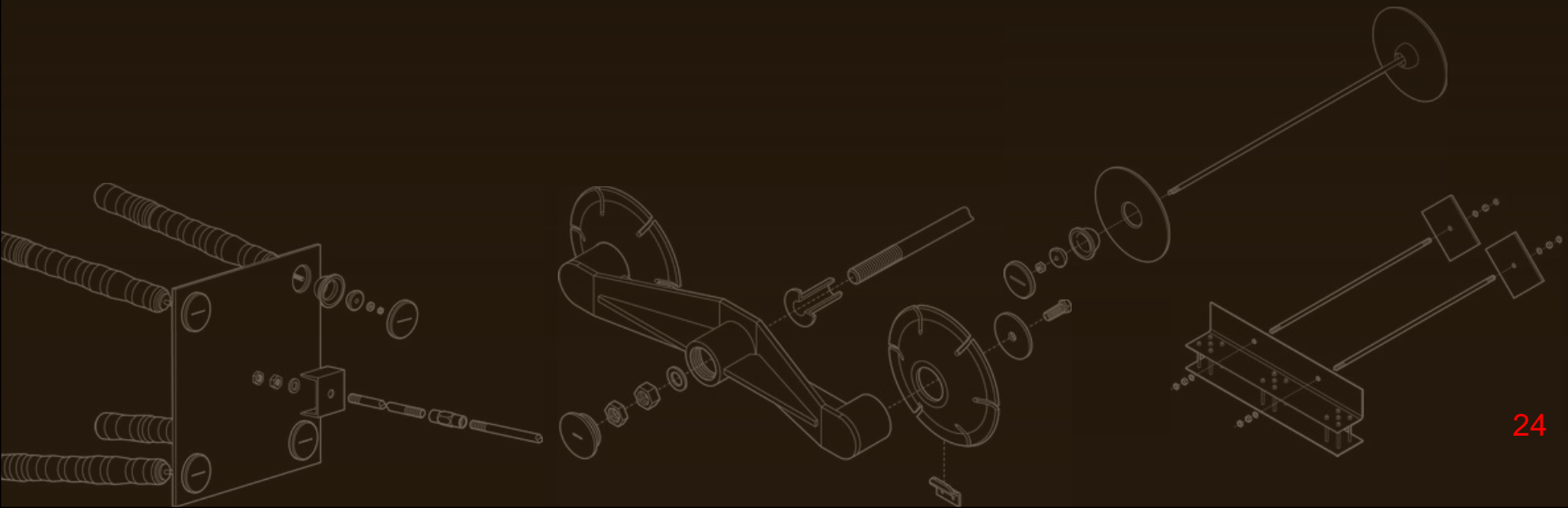

Three types of measures may be devised:

- Improvement of the global stability of the structure;
- Structural rehabilitation of masonry;
- Structural rehabilitation of timber.

Some examples...

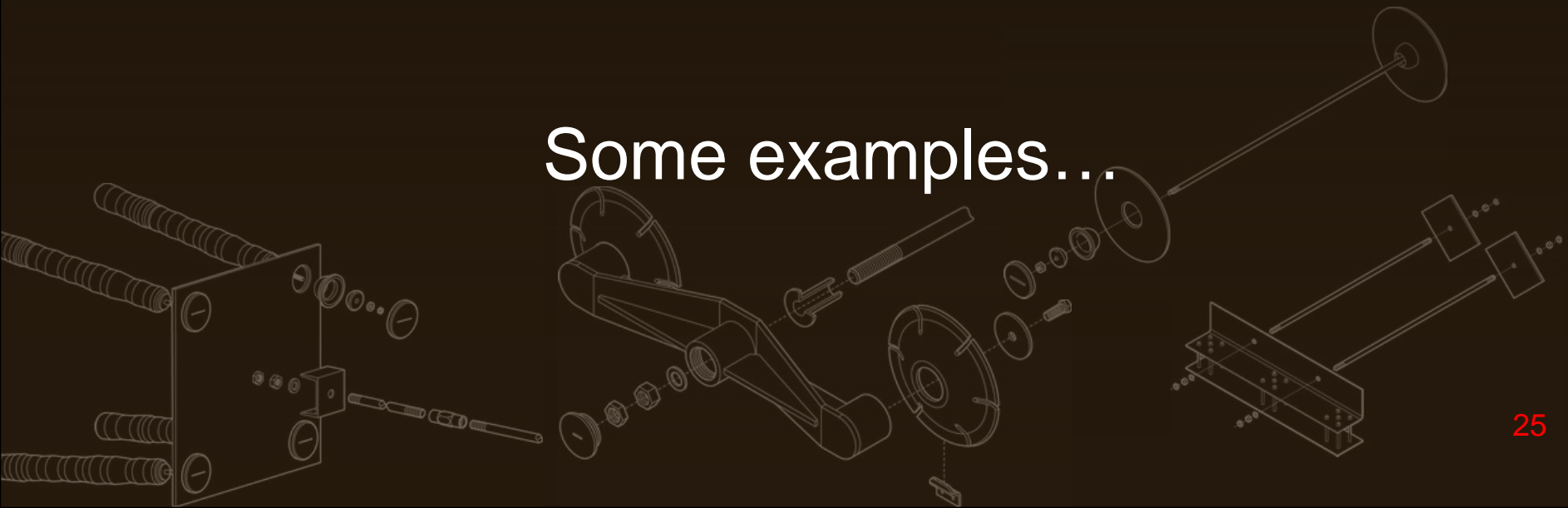

Improvement of the global stability of the structure

- Introduction of new bracing members;
- **Improvement of connections between structural components;**
- Introduction of devices altering the dynamic characteristics of the structure.

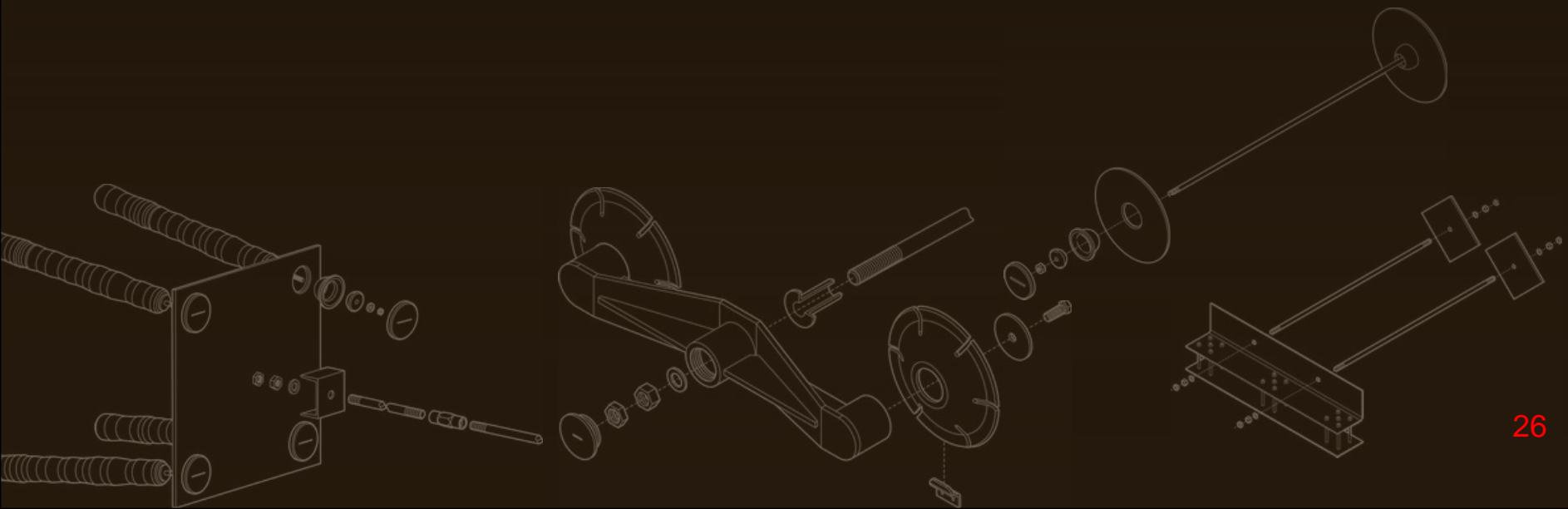

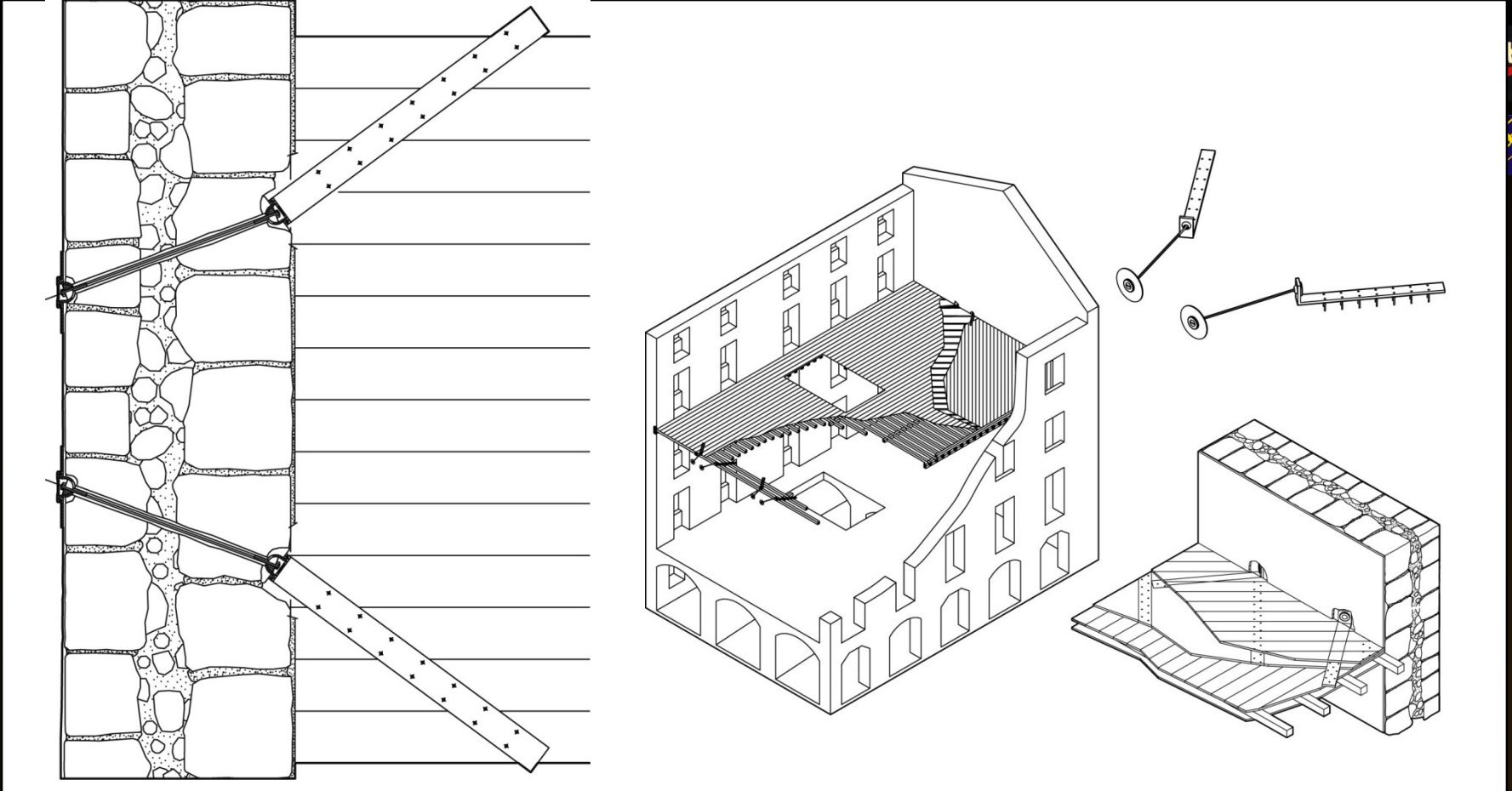

Installation of devices aiming at improving floor/wall connection.

Examples of techniques aiming at improving the global stability of the structure.

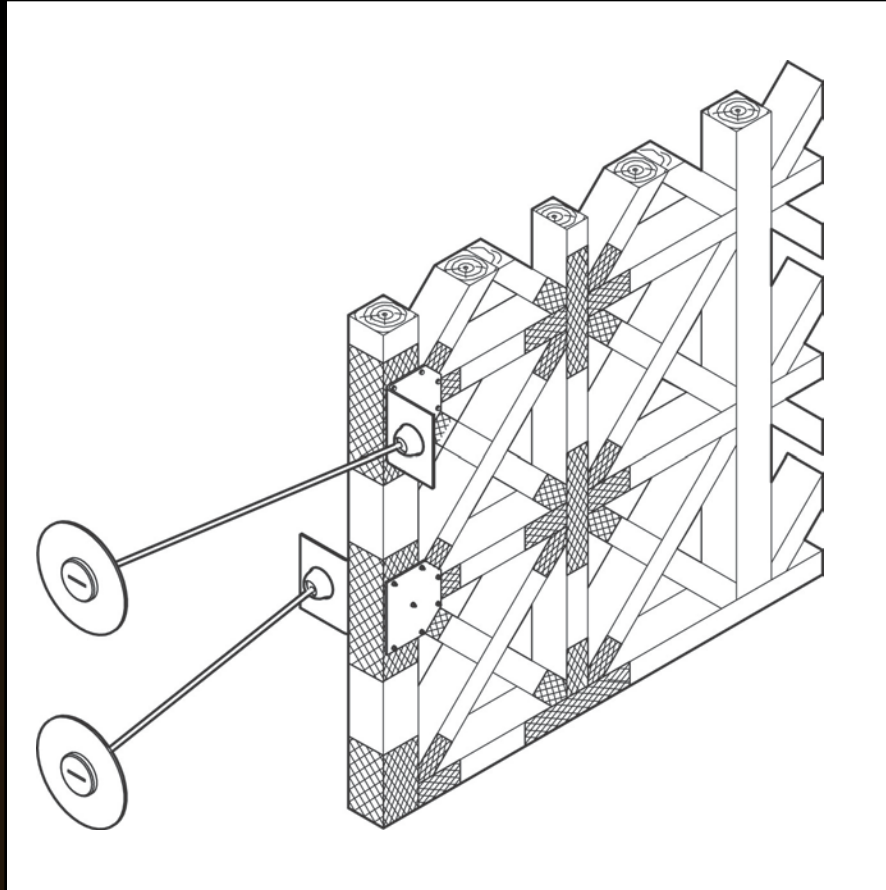

Strengthening the connection between timber bracing walls and main masonry walls. The ties cross the masonry wall. Note the FRP strengthening of the bracing walls.

Examples of techniques aiming at improving the global stability of the structure.

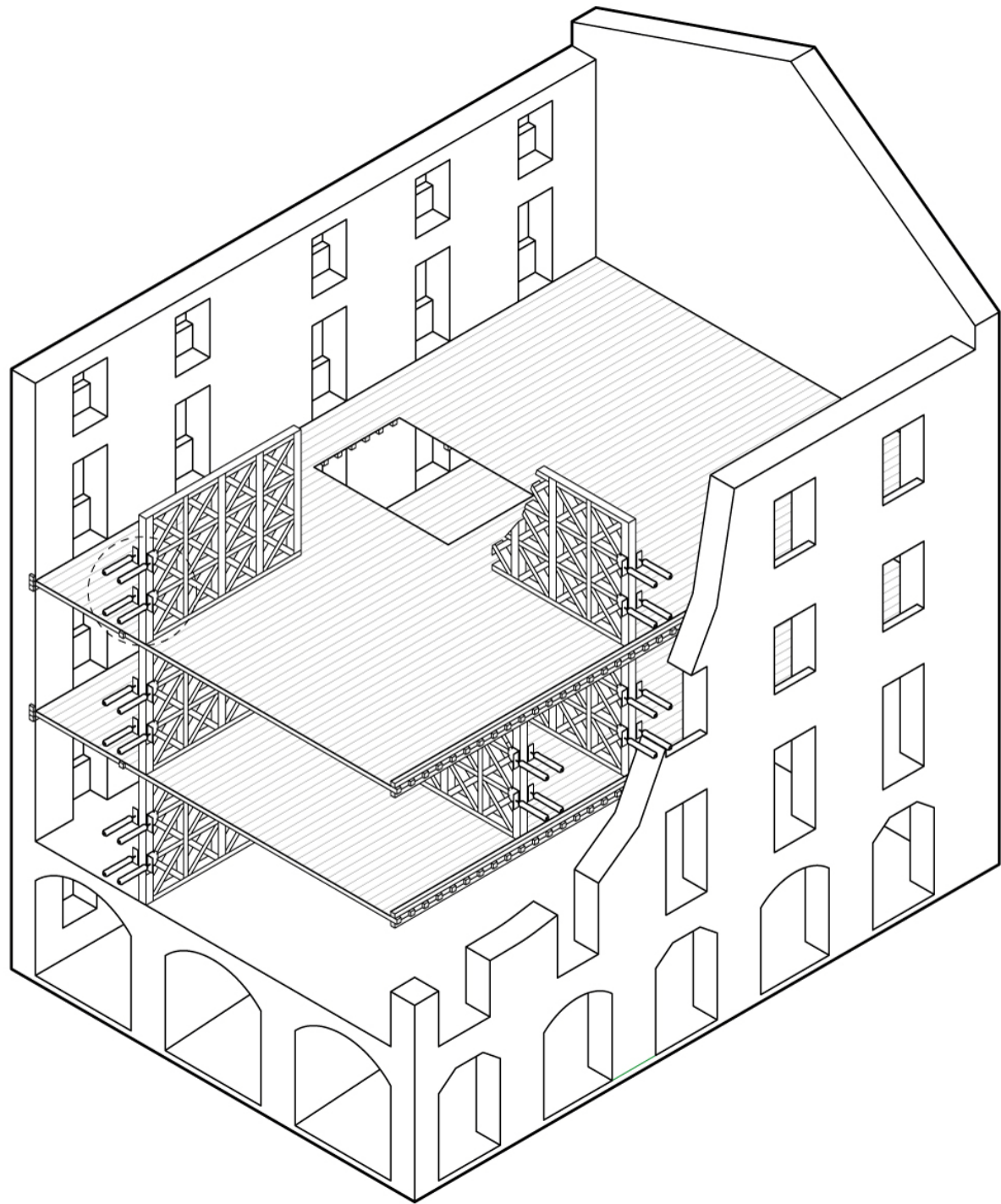
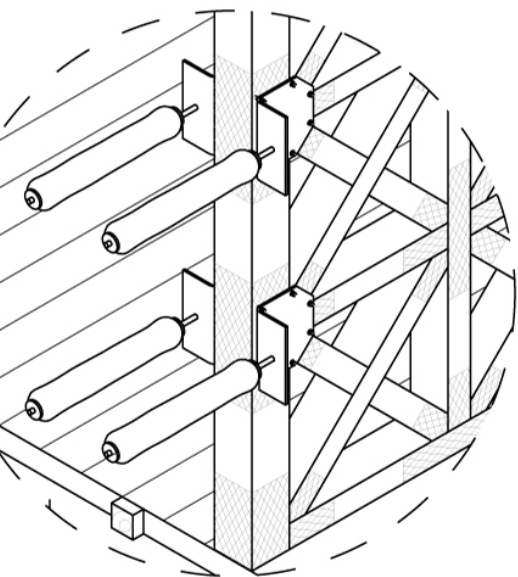

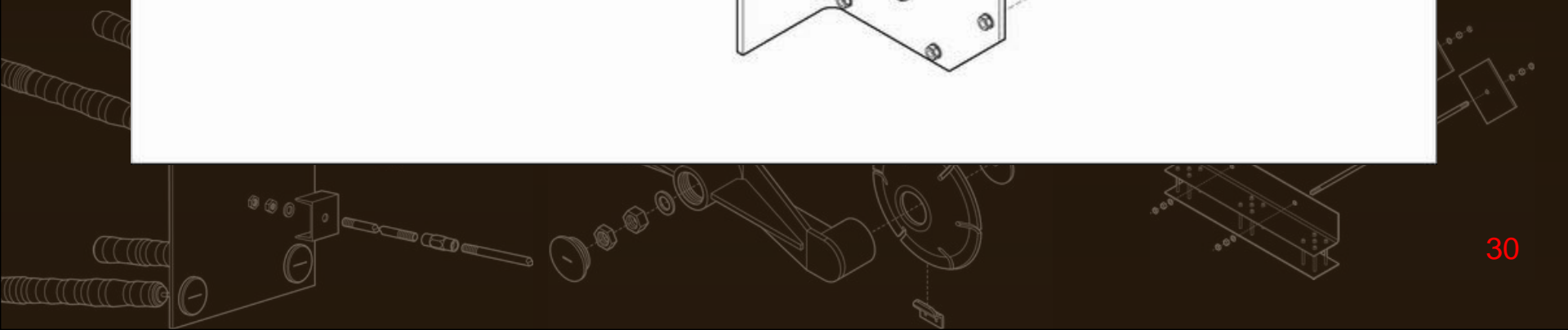
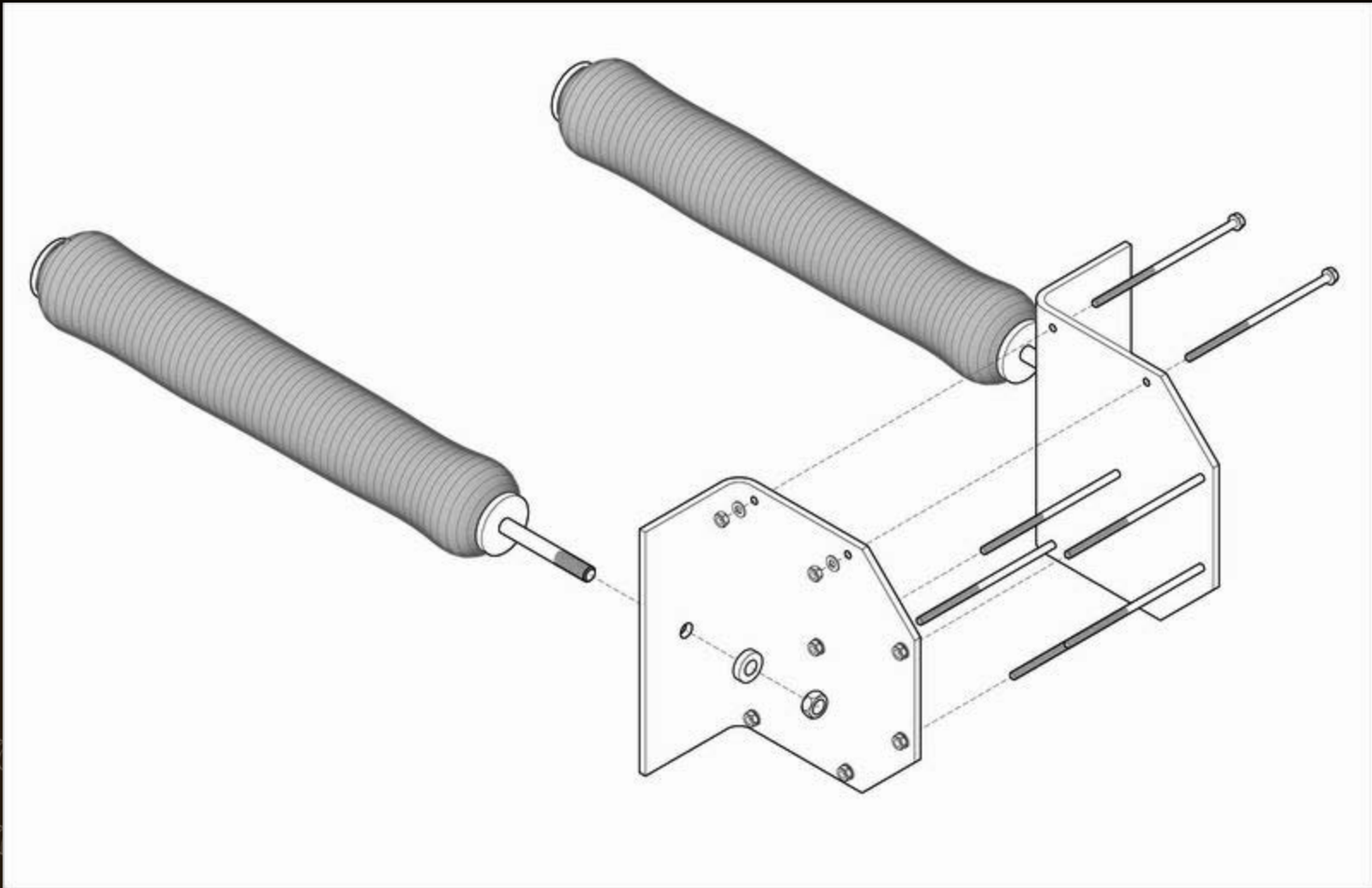

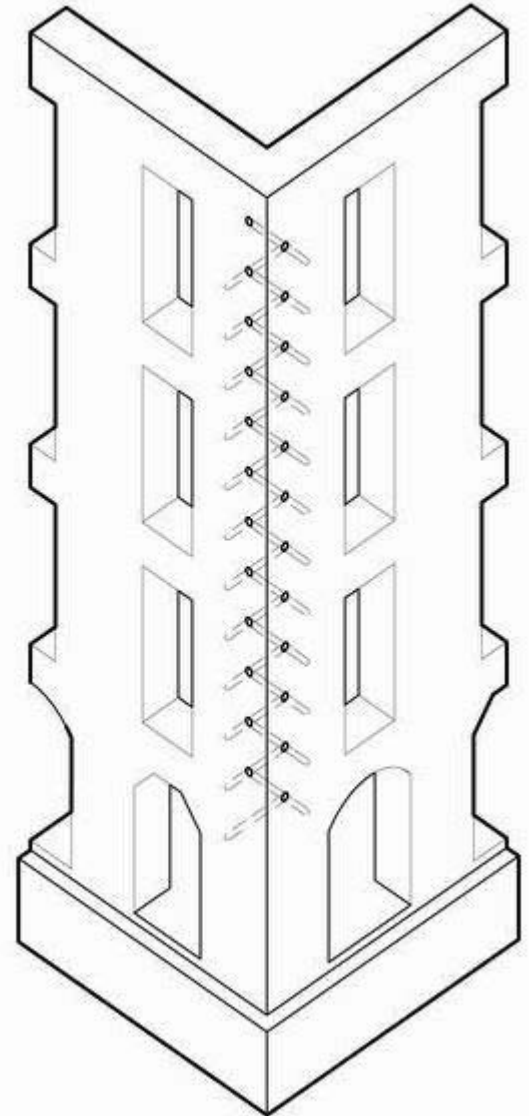
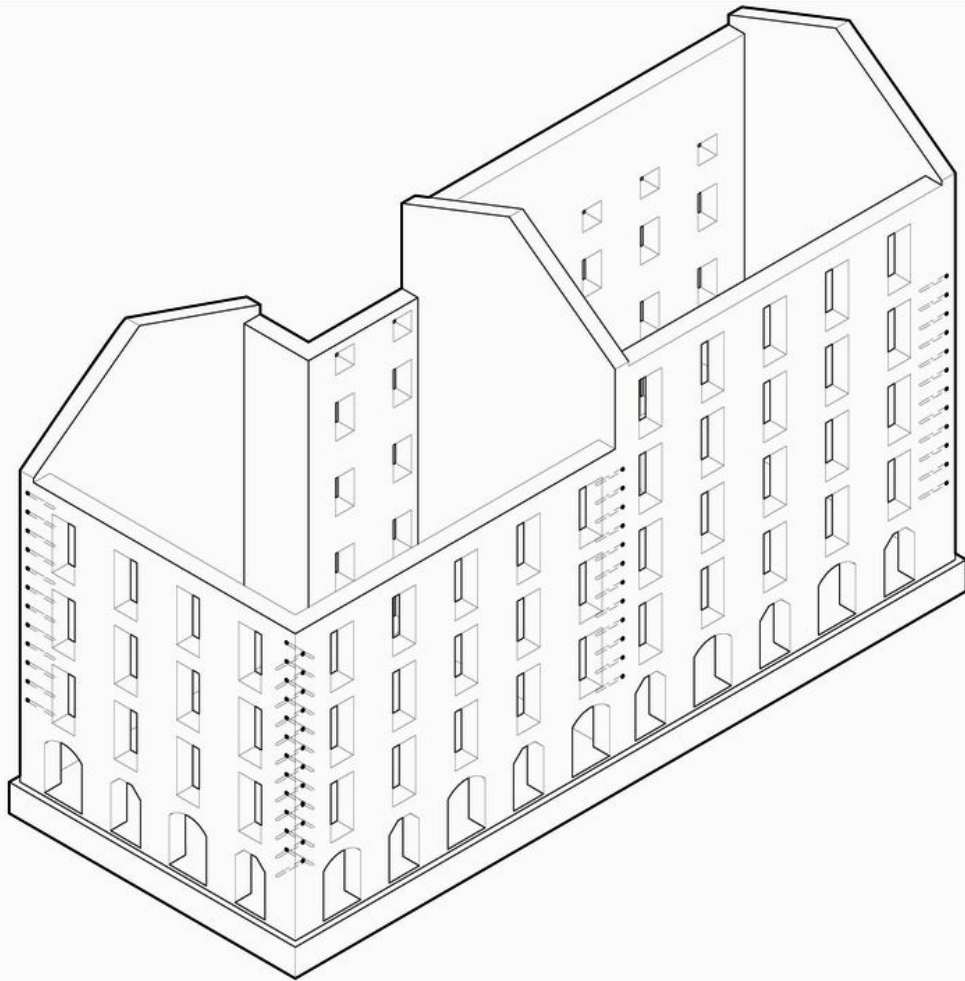

Improvement of the global stability of the structure

- Introduction of new bracing members;
- Improvement of connections between structural components;
- **Introduction of devices altering the dynamic characteristics of the structure.**

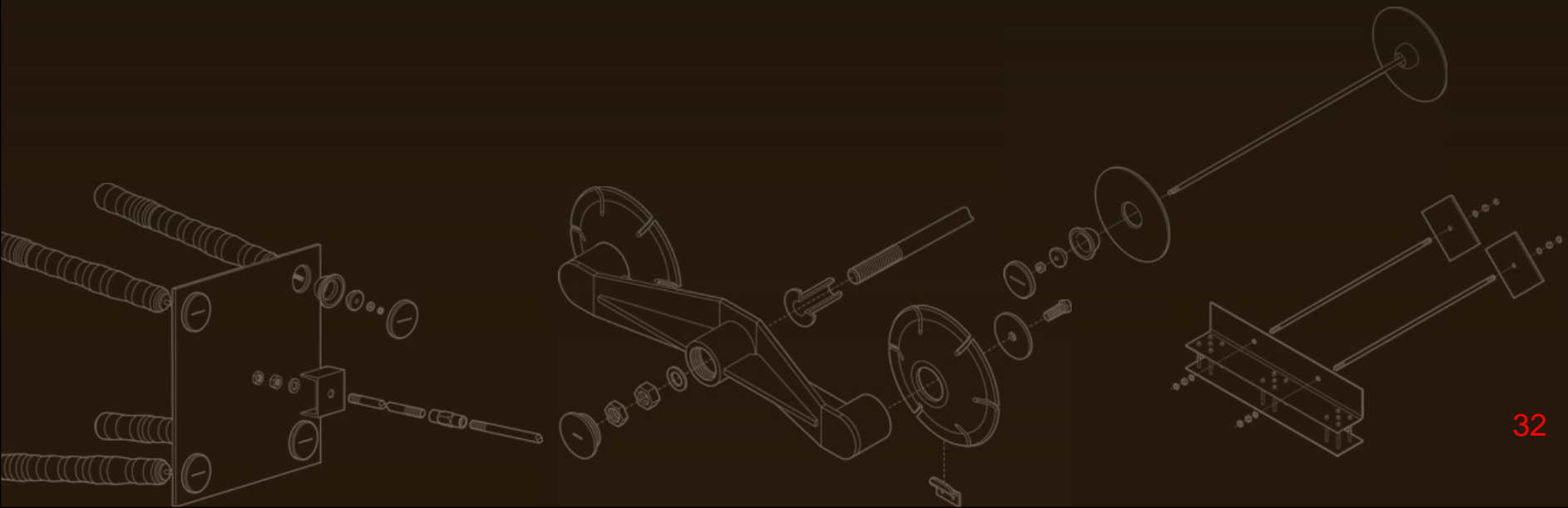

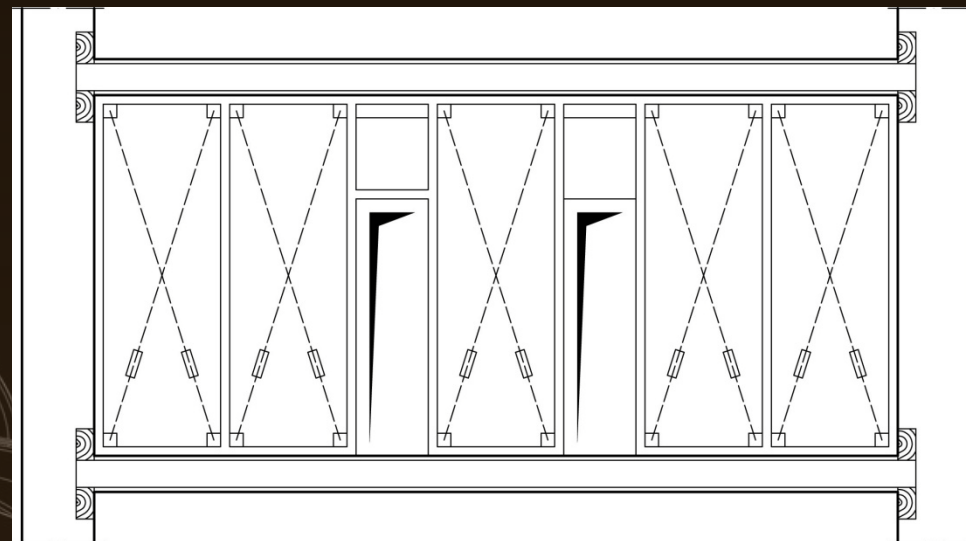
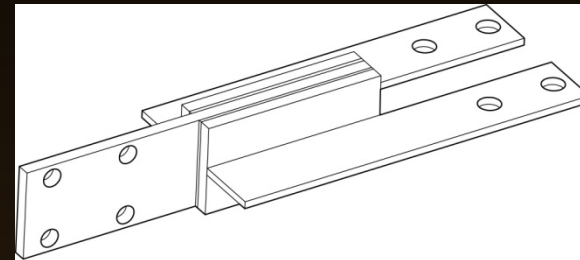
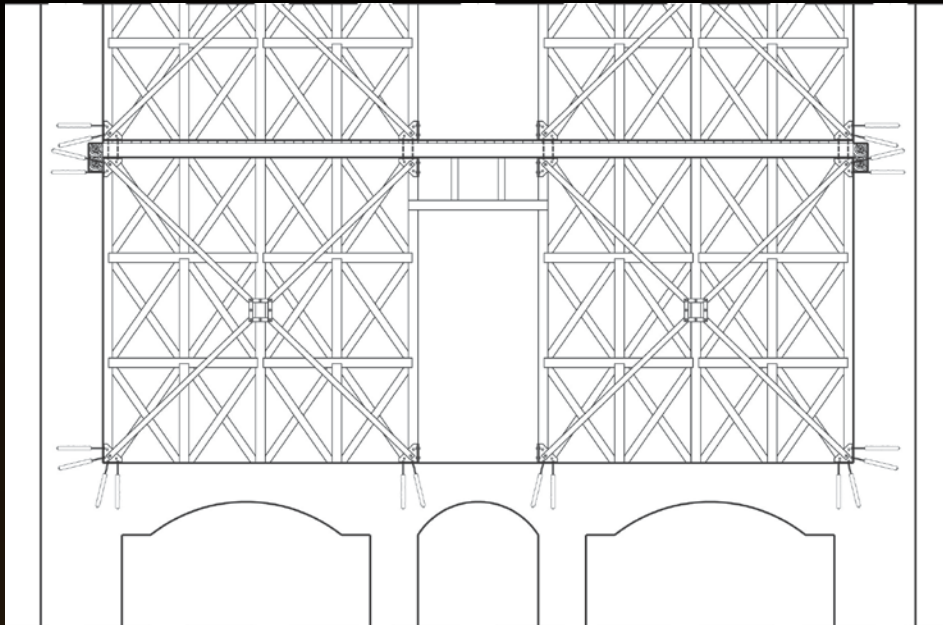

Installation of
damping devices.

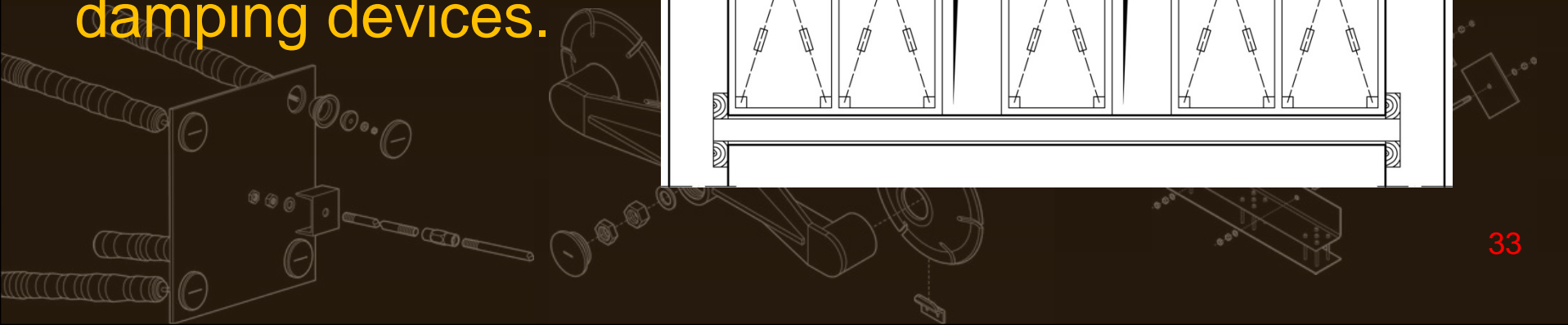

Structural rehabilitation of masonry

- Increasing the strength of the component through confinement;
- Increasing the strength of the component by adding a new material;
- Restoring the section of the element using the material;
- Restoring the section of the element using another material;
- Local increase of strength through the addition of new active members (with load redistribution).

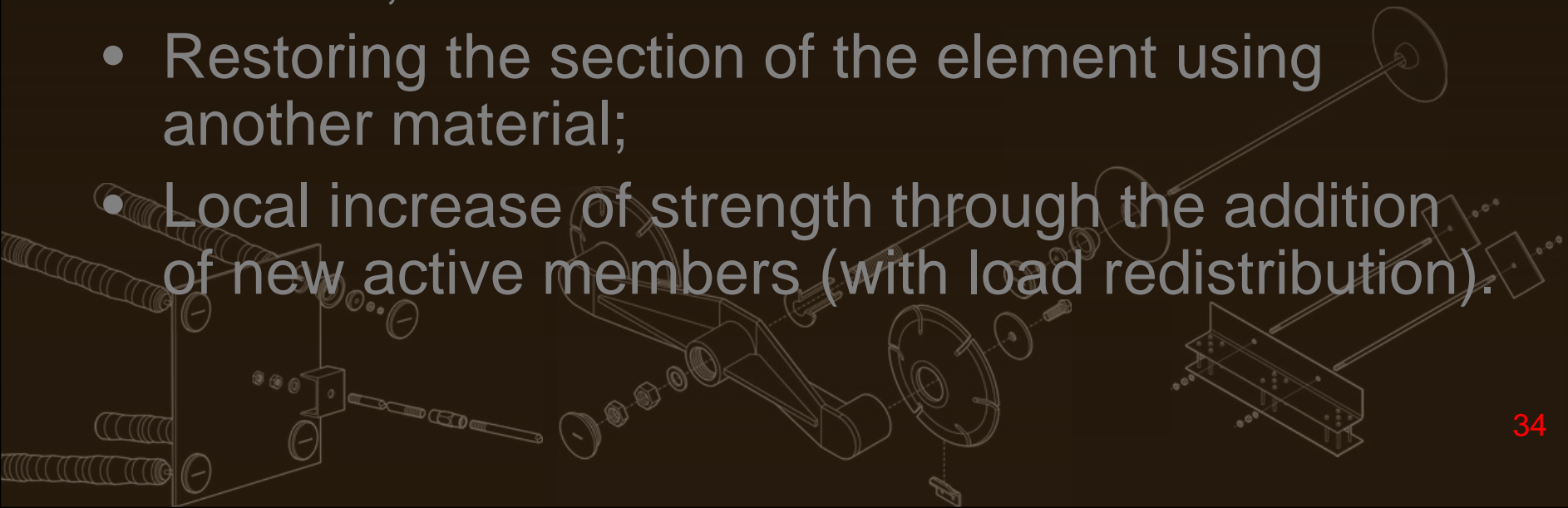

Installation of confining through ties.

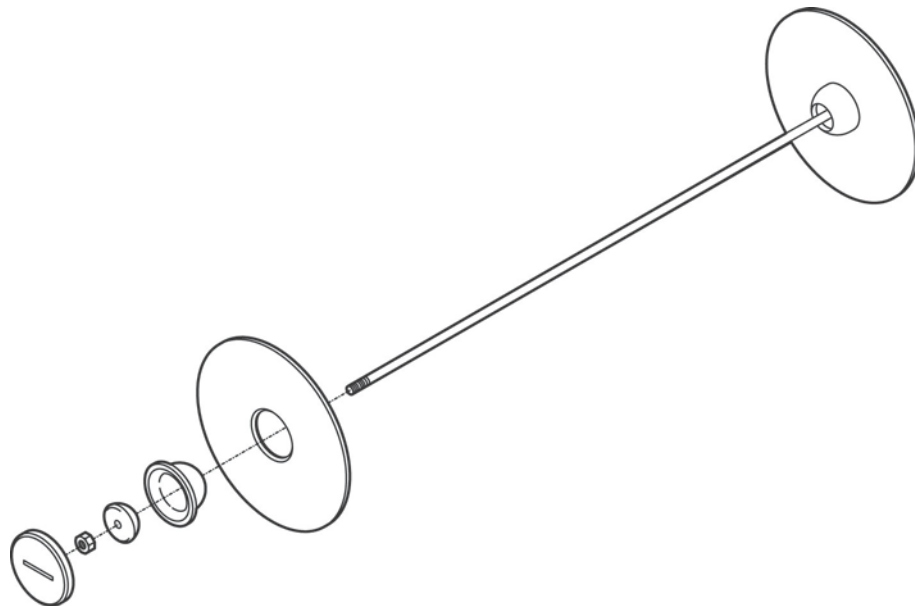
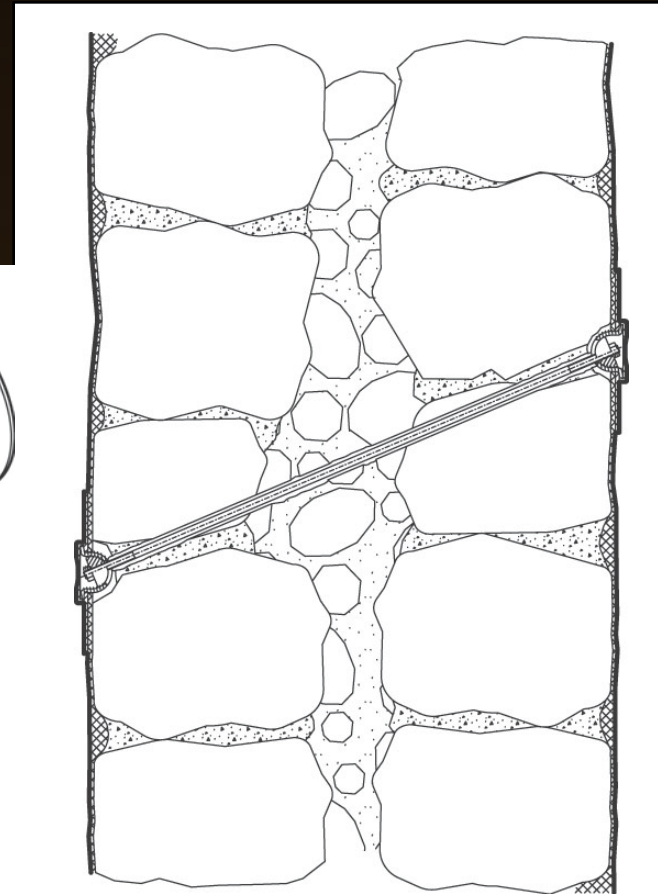
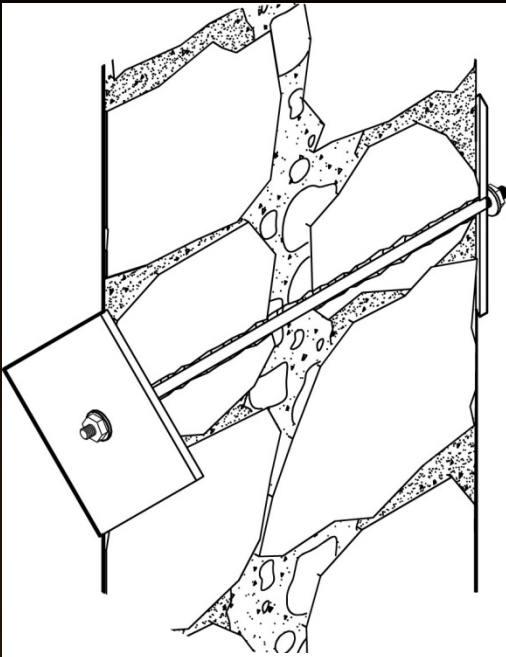

Structural rehabilitation of masonry

- Increasing the strength of the component through confinement;
- **Increasing the strength of the component by adding a new material;**
- Restoring the section of the element using the material;
- Restoring the section of the element using another material;
- Local increase of strength through the addition of new active members (with load redistribution).

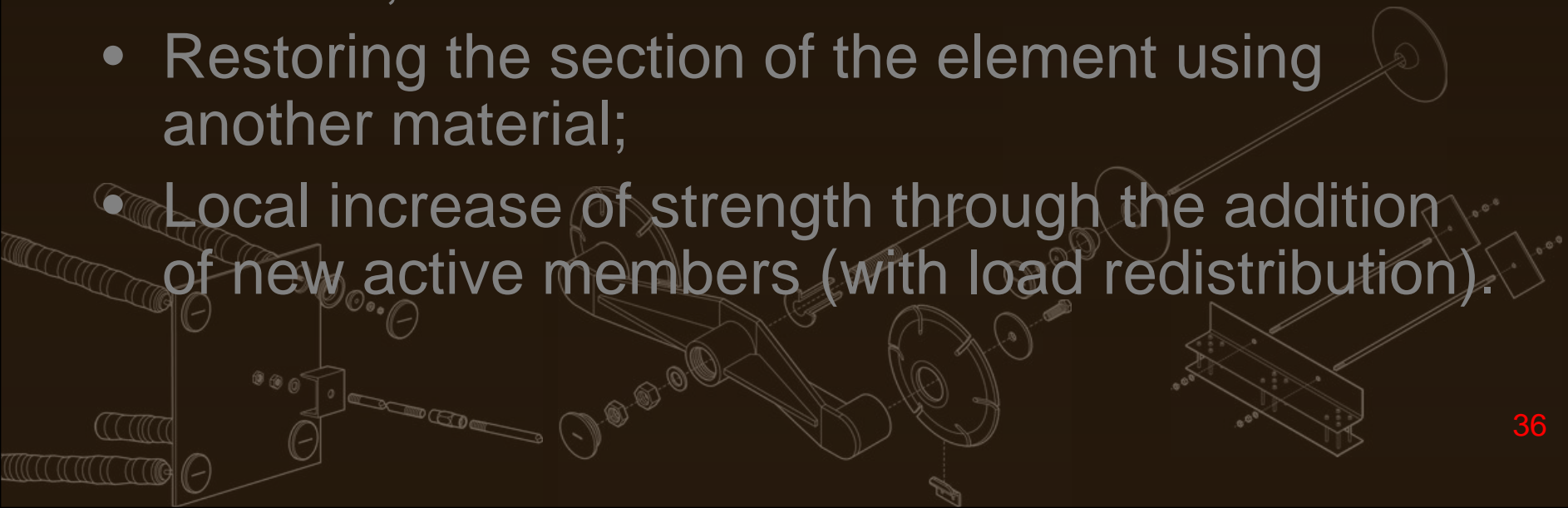

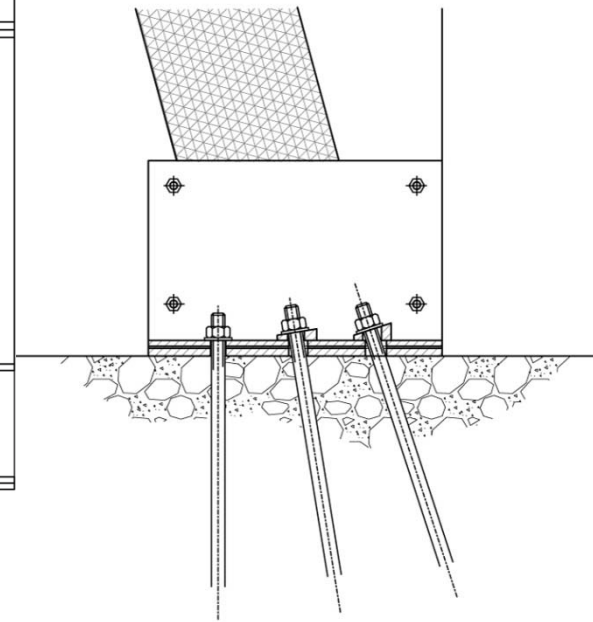
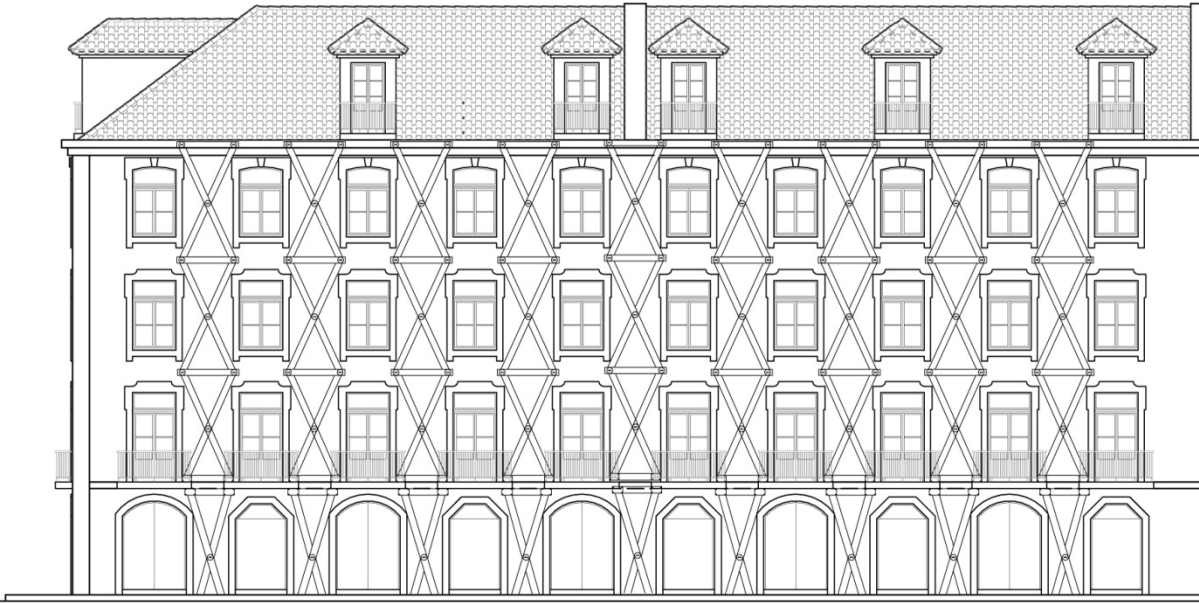

Increasing the strength of the component by adding a new material (FRP bands).

Strengthening the piers by adding a new material (FRP bands), coupled with trough ties.

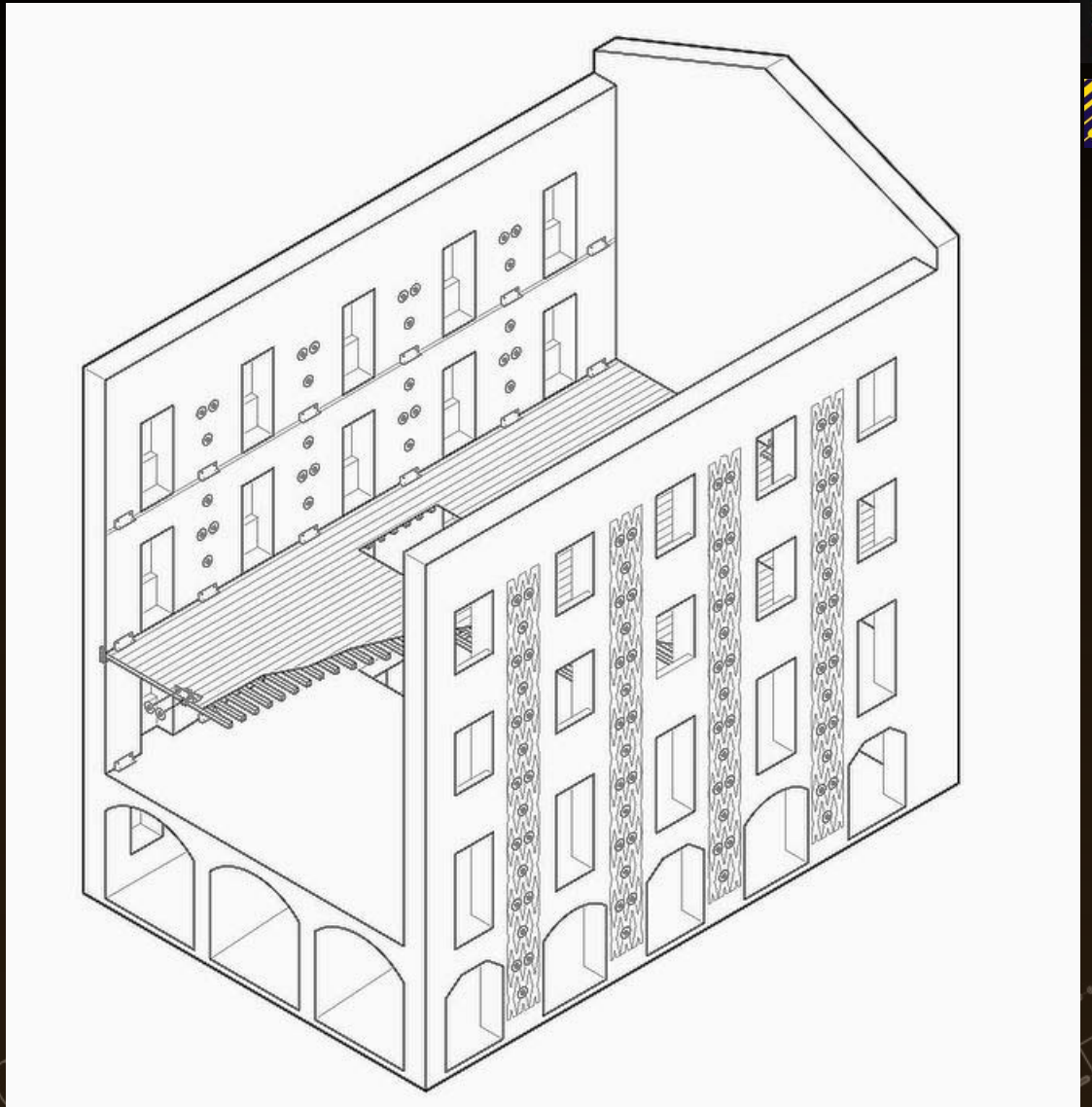

Final remarks

1. The structural rehabilitation of ancient buildings, in general, and those which make up Lisbon's "baixa pombalina" in particular, may be achieved by relatively simple and non-intrusive methods, with a "surgical" nature, enabling intervention without altering the original structural scheme and without increasing significantly the mass of the various components and elements, structural or not. Additionally, such methods enable interventions with tolerable disturbance of the building tenants.

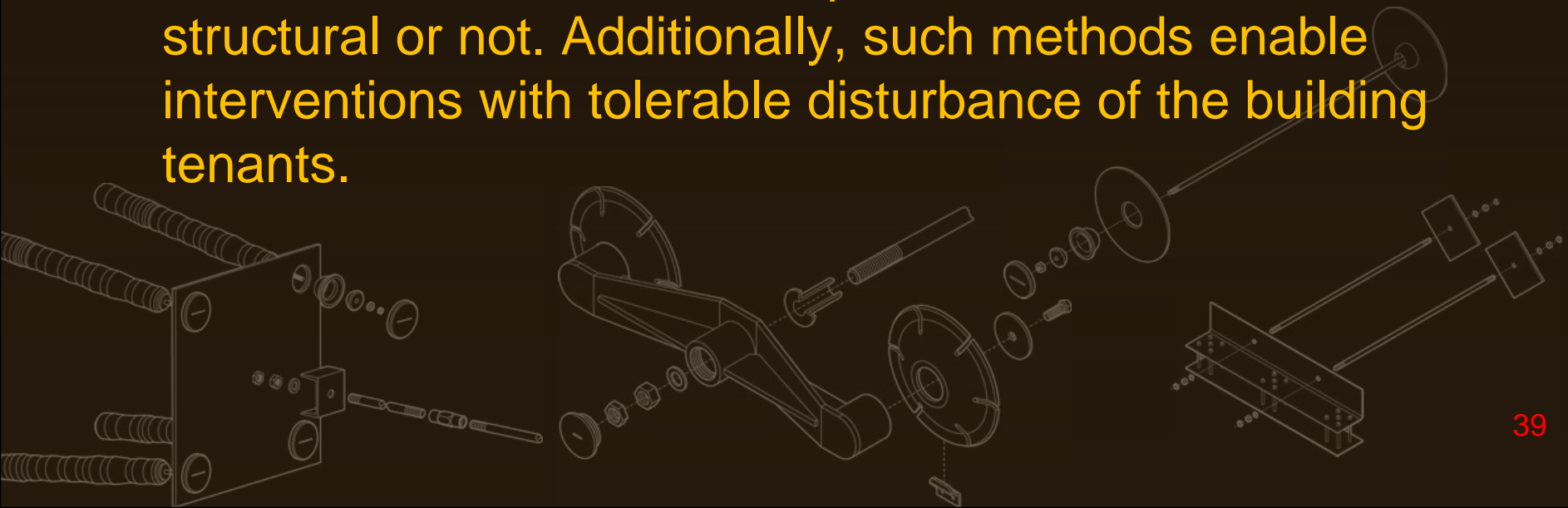

Final remarks

2. These structural solutions, will necessarily link with others of functional nature, which will enable the upgrading of the comfort and living conditions of the buildings, in view of the users wellbeing, either the dwellers or the users at large, in the case of commercial buildings. To answer the needs of conservation and rehabilitation in this field, a large number of systems and equipments are nowadays available in the market.

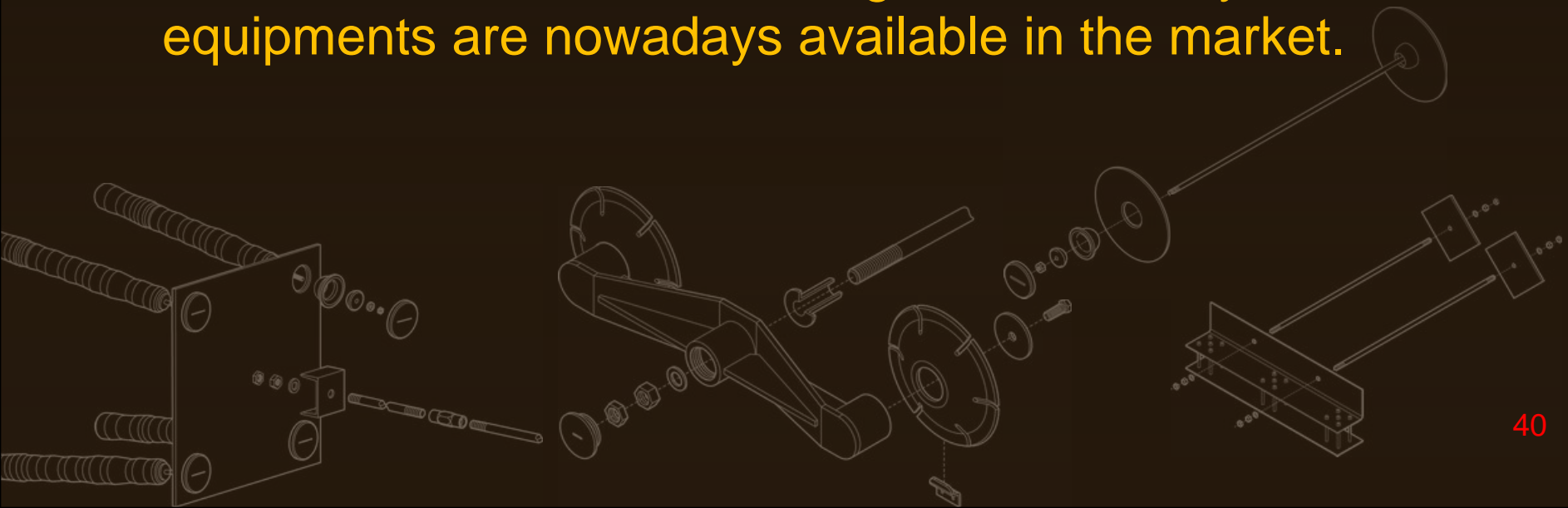

Make up of missing or deteriorated pannels of timber framed walls in a pombalino building, downtown Lisbon. Detail of local strengthening of floor beams.

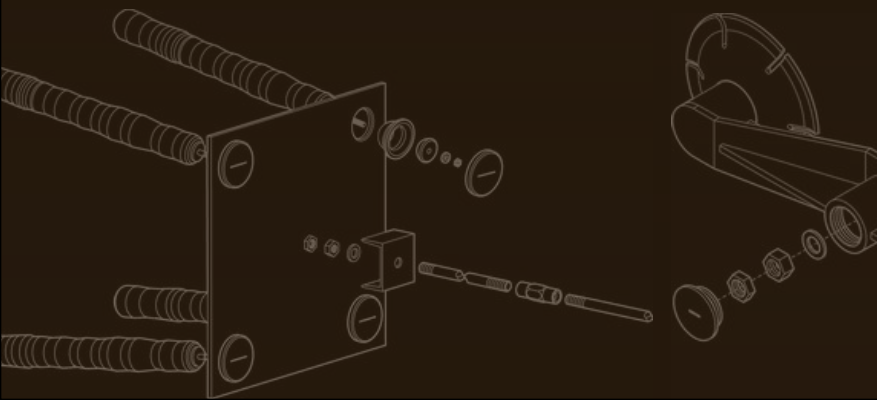

www.oz-diagnostico.pt

www.stap.pt

Thank you.

